

# Dishaa®

COMPLETE FACTORY SET-UP TURNKEY SOLUTIONS

## UNITED ARAB EMIRATES

### DISHAA MACHINERY & TOOLS LLC

Showroom No.2  
Al Qusais Industrial Area-5  
United Arab Emirates  
Contact: Mr. Sajith Srinivasan  
Tel: +971 43290050  
Email: [sajith@dishaagroup.com](mailto:sajith@dishaagroup.com) / [dishaaintl@gmail.com](mailto:dishaaintl@gmail.com)  
[design@dishaagroup.com](mailto:design@dishaagroup.com) / [sales@dishaagroup.com](mailto:sales@dishaagroup.com)  
[enquiry@dishaagroup.com](mailto:enquiry@dishaagroup.com)

### DISHAA INTERNATIONAL LLC

Al Garhoud - Deira  
PO Box: 80899, Dubai, U.A.E  
Tel: +971 043290050, Mob: +971 509696477  
Email: [sajith@dishaagroup.com](mailto:sajith@dishaagroup.com) / [dishaaintl@gmail.com](mailto:dishaaintl@gmail.com)  
[design@dishaagroup.com](mailto:design@dishaagroup.com) / [sales@dishaagroup.com](mailto:sales@dishaagroup.com)

Distributed by:

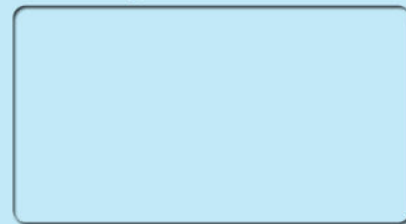

Friendly Reminder: Due to technical and process updates, the product is subject to changes in such as structure, configuration, weight and other parameters without prior notice.

[www.dishaagroup.com](http://www.dishaagroup.com)

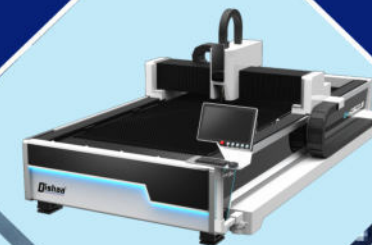



	Page No.
➤ ABOUT US	2
➤ NC Press Brake	4
➤ CNC Press Brake	8
➤ Hydraulic Guillotine (CNC) Shearing Machine	16
➤ Hydraulic Swing Beam Shearing Machine	20
➤ Fiber Laser Cutting Machine	22
➤ Fiber Laser Cutting with Tube Cutting	28
➤ Laser Marking Machine	32
➤ Laser Cleaning Machine	42
➤ Laser Welding Machine	44
➤ CNC Table Type Plasma Cutting Machine	46
➤ CNC Gantry Type Plasma Cutting Machine	47
➤ CNC 4- Roller Plate Rolling Machine	48
➤ 3 Roller Plate Rolling Machine	52
➤ Iron Worker	56
➤ H Frame Press Machine	58
➤ Pneumatic Press Machine	60
➤ Hydraulic Press Machine	61
➤ Power Press	68
➤ Arbor Press	69
➤ NC Lathe Machine	70
➤ Heavy Duty Lathe Machine	78
➤ Pipe Threading Lathe Machine	80
➤ CNC Lathe Machine	82
➤ EDM Machine	90
➤ CNC EDM Machine	92
➤ Drilling & Tapping Machine	96
➤ Electric Tapping Machine	97
➤ Bench Drilling Machine	98
➤ Magnetic Drilling Machine	99
➤ Vertical Drilling Machine	100
➤ Radial Drilling Machine	106
➤ Drilling & Milling Machine	116
➤ Vertical Milling Machine	120
➤ Horizontal Milling Machine	122
➤ Turret Milling Machine	124
➤ Rotary Head Milling Machine	128
➤ Bed Type Milling Machine	130
➤ Vertical Machining Centre	132





➤ Shaper Machine	136
➤ Circular saw Machine	138
➤ Hacksaw Machine	139
➤ Bandsaw Machine	140
➤ 3-in 1 Combination of Shear, Brake and Roll Machine	148
➤ Electric Shearing Machine	150
➤ Manual Shearing Machine	151
➤ Manual Folding Machine	152
➤ Pan & Box Brake Machine	153
➤ Slip Roll Machine	154
➤ Bead Bending Machine	156
➤ Rotary Machine	157
➤ Bench Grinder	158
➤ Lock Former	159
➤ NC Pipe Bending Machine	160
➤ CNC Pipe Bending Machine	164
➤ Manual Pipe Bending Machine	168
➤ Electric Pipe Bending Machine	169
➤ Profile Bending Machine	170
➤ Threading Machine	174
➤ Pipe Support Stand	175
➤ Hand Pallet	176
➤ Stacker	177
➤ Gallery	180

## About us

### Why choose us!!!

An ISO 9001, 14001 & 45001 certified company, **Dishaa** is the most trusted **“TRADEMARK REGISTERED”** Machinery Brand of UAE providing quality machinery and after sales services since 1992.

Today **Dishaa** is a name synonym with Precision, Quality, Reliability & Performance when it comes to setup of engineering & armoring companies in the region. Our longstanding reputation in the market has been achieved with humble and consistent quality, performance and excellent after sales service support. We are one of the first to introduce a warranty of 2-years for our machines in the region, this speaks volumes about the trust we have in our machine performance and quality.

All our press brakes and shearing machines are **“CE CERTIFIED”** with lifelong spare parts support. Our team of well-trained engineers gives an excellent timely online or onsite **“AFTER SALES SERVICE SUPPORT”**, so you don't have to worry about the downtime in production. Our client list encompasses all major oil & gas service providers, defense sectors, armoring companies, heavy & medium fabrication industries, precision toolroom facilities, maintenance workshops, automobile and aerospace sectors.

We are proud to announce that we have been awarded the **“BEST INDUSTRIAL MACHINERY & TOOLS COMPANY”** for the 5 consecutive years since 2019-2023 by **MEA UAE BUSINESS AWARDS**.

Be it machinery upgradation, new factory setup or purchase of new machines – speak to us today for un-matched offers and solutions. When you consider quality with pricing, **Dishaa** machines are the best in the Region.

**DISHAA MACHINERY & TOOLS LLC - “COMPLETE FACTORY SETUP TURKEY SOLUTIONS.”**





## Torsion Bar Press Brake

### Performance

The bending machine frame is integrally processed by a large floor boring and milling machine.  
 The forged material shaft body has good rigidity and elasticity, and has a fine adjustment device, which is weak against the partial load.  
 The user can customize the mold segments 10, 15, 20, 30, 50, 100, 300 (cm).  
 Use ESTUN or DELEM brand CNC system for users to choose.  
 In the system, the plate thickness and length parameters are input, and the system will automatically perform deflection compensation.  
 It adopts ball screw and linear guide, which is driven by servo motor, and the back gauge is positioned quickly and accurately.  
 The height of the finger is designed from the overall adjustment, and the height of the finger can be adjusted manually.  
 Improve the replacement mold speed and improve work efficiency.



- Optional Controllers**
- China ESTUNE300、E300P
  - Holland DELEM DA41T
  - German ELGO P40
  - Italy HT072
  - Swiss Cybelec Touch 8

### Sample Display

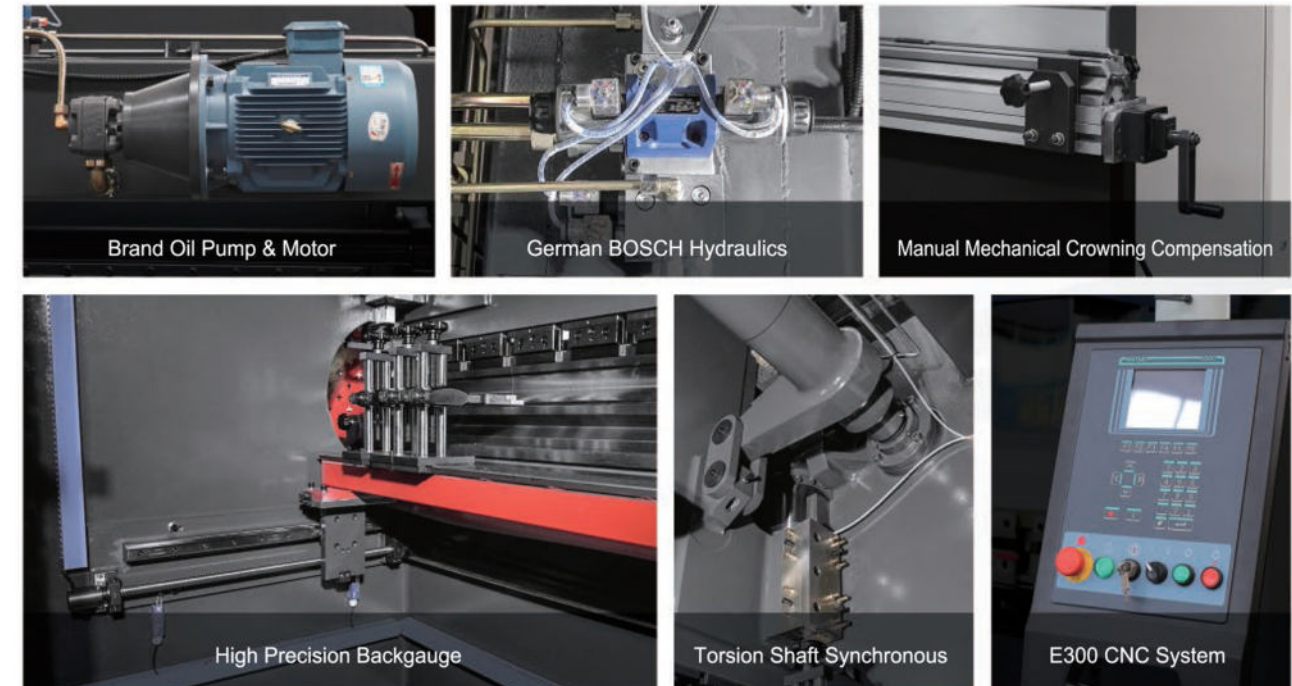

## Torsion Bar Plate Press Brake

Standard Economic NC System

China ESTUN E21



**Optional**  
Manual Mechanical Crowning Compensation



## NC Controller

### E21



Positioning control of back gauge.  
Intelligent positioning control.  
One-side and two-side positioning which eliminates spindle clearance effectively.  
Retract functions.  
Automatic reference searching.  
One-key parameter backup and restore.  
Fast position indexing.  
40 programs storage space, each program has 25 steps.  
Power-off protection.

### E300P



10" high definition full color LCD touch screen is adopted  
X, y, R servo axis controlled by CAN bus;  
Deflection compensation supports mechanical and hydraulic modes;  
Built in machine action logic, multiple action modes;  
Built in mold library and material table can be edited;  
I / O port can be configured freely;  
USB interface is configured to facilitate backup and upgrade;  
Built in parameter backup / recovery function;  
Chinese/English, mm/inch.

### E300



Support x, y, R axis servo control, c axis hydraulic compensation / mechanical compensation mode;  
Built in machine control logic, hydraulic valve logic free configuration, I / O function port free configuration;  
Accurate angle programming calculation function;  
Standard USB interface;  
Standard EDS / Pronet series servo;  
Safety zone protection, collision detection, R-axis collision avoidance positioning function;  
Built in parameter backup and one click recovery function;  
Support one page programming;  
Micro switch key board;  
Integrated suspension;  
Can bus servo control technology;  
High Definition LCD display, Chinese / English optional, male / English optional.

### DA-41T



Panel based housing  
Bright LCD screen  
Beam stop control (Y)  
Backgauge control (X)  
Retract functionality  
Manual movement of all axes  
Backgauge control (R) (DA-42T)  
Crowning function (DA-42T)  
Pressure control (DA-42T)

### CT8



8" color LCD display, touch screen, icon recognition function;  
The "EasyBend" page is processed with easy single bending.  
The fully efficient bending programming can meet the needs of mass production and processing.  
Automatically calculate bending angle, main pressure and deflection compensation;  
Automatic calculation of bending data;  
Automatic calculation of pressure and deflection compensation; automatic calculation of upper die depth;  
Angle, Back Gauge correction;

## Technical Parameters

Type	Nominal Force ( KN )	Worktable Length ( mm )	Poles Distance ( mm )	Throat Depth ( mm )	Slider Travel ( mm )	Max Open ( mm )	Power ( kw )	Weight ( kg )	Dimension LxWxH ( mm )
40T/2200	400	2200	1850	220	100	320	5.5	2750	2200x1200x1910
40T/2500	400	2500	1850	220	100	320	5.5	3000	2500x1200x1910
50T/2200	500	2200	1850	220	100	320	5.5	2950	2200x1200x1910
50T/2500	500	2500	1850	220	100	320	5.5	3400	2500x1210x2000
63T/2500	630	2500	1900	260	120	320	5.5	4000	2500x1300x2210
63T/3200	630	3200	2560	260	120	320	5.5	4800	3200x1300x2210
80T/2500	800	2500	1980	320	120	320	7.5	5700	2500x1400x2300
80T/3200	800	3200	2650	320	120	350	7.5	6020	3200x1500x2300
80T/4000	800	4000	3350	320	120	350	7.5	7000	4000x1500x2400
100T/2500	1000	2500	1980	320	150	400	7.5	6000	2500x1600x2400
100T/3200	1000	3200	2650	320	150	400	7.5	6800	3200x1600x2600
100T/4000	1000	4000	3350	320	150	400	7.5	8400	4000x1600x2700
125T/2500	1250	2500	1980	320	150	400	11	6500	2500x1600x2400
125T/3200	1250	3200	2650	320	150	400	11	7200	3200x1600x2600
125T/4000	1250	4000	3350	320	150	400	11	8800	4000x1600x2700
160T/3200	1600	3200	2650	320	200	460	11	10500	3200x1700x2700
160T/4000	1600	4000	3350	320	200	460	11	11500	4000x1700x2800
160T/5000	1600	5000	4000	320	200	460	11	14000	5000x1900x3100
160T/6000	1600	6000	4900	320	200	460	11	19500	6300x1900x3200
200T/3200	2000	3200	2650	320	200	460	11	12500	3200x1950x2800
200T/4000	2000	4000	3350	320	200	460	11	13600	4000x1950x2800
200T/5000	2000	5000	4000	320	200	460	11	14500	5000x1950x3100
200T/6000	2000	6000	4900	320	200	460	11	21000	6000x1950x3300
250T/3200	2500	3200	2500	400	250	530	18.5	19000	3250x2000x3200
250T/4000	2500	4000	2900	400	250	530	18.5	20200	4000x2000x3400
250T/5000	2500	5000	4000	400	250	530	18.5	23500	5000x2000x3400
250T/6000	2500	6000	5000	400	250	530	18.5	27500	6000x2000x3400
300T/3200	3000	3200	2500	400	250	530	22	20500	3200x2000x3450
300T/4000	3000	4000	2900	400	250	530	22	22500	4000x2000x3450
300T/5000	3000	5000	4000	400	250	530	22	25000	5000x2000x3450
300T/6000	3000	6000	5000	400	250	530	22	30000	6000x2000x3450
400T/4000	4000	4000	2900	400	250	530	30	25000	4000x2180x3500
400T/5000	4000	5000	4000	400	250	530	30	29000	5000x2180x3500
400T/6000	4000	6000	5000	400	250	530	30	35000	6000x2180x3800
500T/4000	5000	4000	2900	400	320	590	37	35000	4000x2580x3500
500T/5000	5000	5000	4000	400	320	590	37	44000	5050x3500x3700
500T/6000	5000	6000	5000	400	320	590	37	55000	6050x3500x3700
600T/4000	6000	4000	2900	400	320	590	45	45000	4050x4500x3700
600T/6000	6000	6000	5000	400	320	590	45	60000	6050x4500x3700

Parameters change without notice. All the sizes above models are suitable for tandem.

## NC Controller

ESTUN: E21、E300/E300P  
Holland DELEM: DA41/DA41T、  
Cybele: CT8



## DMB Series

### CNC Hybrid-Electro Servo Press Brake

#### Performance

- The system consumes less energy with the servo motor.
- Oil distribution according to needs has no restriction loss to achieve the energy-saving indeed.
- Low temperature-rise reduces the risk of oil leakage, which has better stability and can increase the working life of hydraulic press system and oil cylinder.
- Gear pump reduces working noise and sensitivity of oil cleanliness, low maintenance
- Precision of ram position or manufacture isn't lower than proportional valve control system, even higher. The ram repositioning precision is  $\pm 0.01\text{mm}$ , highest precision will be  $\pm 0.005\text{mm}$ .
- The consumption of hydraulic oil reduces 70%.
- The simpler installation method can improve efficiency.
- Flexible installation meets populous needs.
- Better economic and higher performance-to-price ratio.



#### SVP

DMB-SVP Series CNC Hybrid-Electro Servo Press Brake

#### Servo Motor

- Using servo motor as the main power source of hydraulic pump can save about 40% energy
- The overall efficiency of the slider increases by about 7-20%
- Oil temperature can be reduced by about 10-20 °C

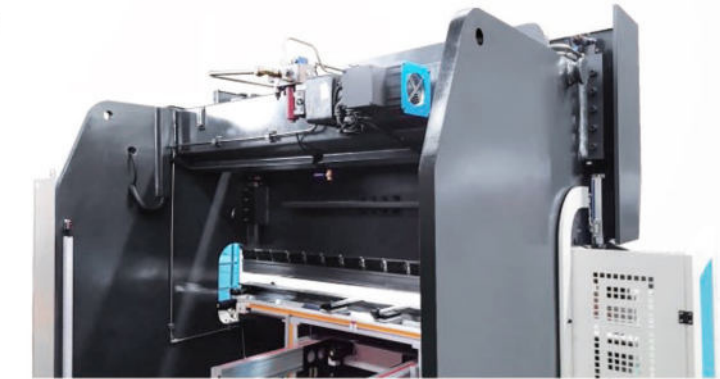

SVP Single Servo Main Motor CNC Press Brake

#### ESVP

DMB-ESVP Series CNC Hybrid-Electro Double Servo Press Brake

#### HOERBIGER ePrAX® Control

- High efficiency and energy saving, oil tank capacity reduced by 70%
- Fast-performance and duty cycle reduction 10%
- Compared with the traditional system, energy efficiency 50% up
- The positioning accuracy of precision-up to  $5\mu\text{m}$
- Integrated servo pump
- Lower-noise at work integrated pressure filters ensures high stability and long service life



ESVP Double Servo Pump Control CNC Press Brake

#### OPTIONAL CNC



DELEM DA53T



DELEM DA58T



DELEM DA66T



DELEM DA69T



CYBELEC CT12



ESA S640



## DMB Series CNC Hydraulic-Electro Servo Press Brake

### Performance

The fuselage adopts the welded structure of the split plate, which is tempered by the large tempering furnace equipment to eliminate the deformation caused by the welding stress and the processing stress to ensure the precision of the machine.

Closed loop control mode composed of electric-hydraulic servo valve and measure ruler.

Ensure the highest control precision, bending accuracy and repositioning accuracy are also reach to the highest level.

Back gauge mechanism can be multi-axes controlled.

Integrated hydraulic system decreases the pipe connections, oil leakage, and increases the stability and overall beautifies.

Worktable equipped with hydraulic and mechanical compensation to avoid the deformed upper beam from affecting the quality of the work piece, it is adjusted automatically by the CNC controller with convenient and accuracy.

CNC controller normally uses Holland DELEM, Italy ESA, Swiss CYBELEC, all with multi-languages.



### Standard Equipment

- Hydraulics by Germany BOSCH / HOERBIGER
- Servo drive and motors by Nanjing ESTUN
- Grating ruler by Spain FAGOA, Germany HEIDENHAIN
- Ball screw and linear guide by Taiwan HIWIN
- Main electric by France SCHNEIDER
- Hydraulic compensation or mechanical compensation.
- Manual adjustable front support with linear.



Germany BOSCH Hydraulics & Pump



U.S.A Sunny Oil Pump

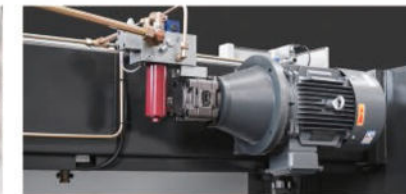

Double Linear Guide

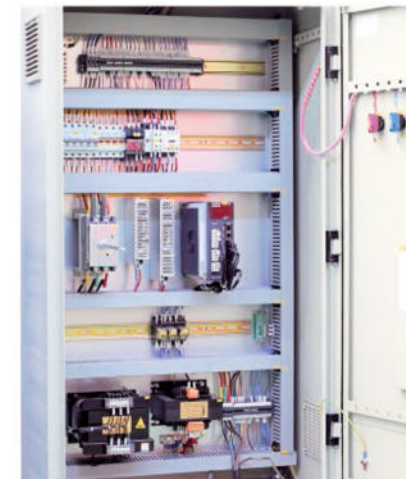

Schneider Electrics



Optional Multiple Axes With More Function

### Optional Equipment

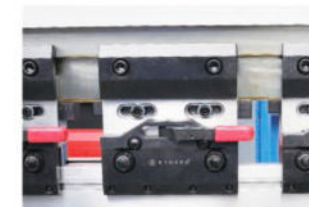

Japan KYOKKO Fast Clamping



Boke Backgauge



WILA Hydraulic Clamps



Laser Guards



## CNC Controller

CNC PRESS BRAKE

CNC PRESS BRAKE



### DA53T

- "Hot-key" touch navigation
- 10.1" high resolution colour TFT
- Up to 4 axes (Y1, Y2 + 2 aux axes)
- Crowning control
- Tool / material / product library
- Servo and frequency inverter control
- Advanced Y-axis control algorithms for closed-loop as well as open-loop valves.
- TandemLink (option)
- USB memory stick interfacing
- Profile-T offline software



160T/3200  
DA53T



### DA58T

- 2D graphic touch screen programming mode
- 15 "high-resolution TFT true color display
- Bending process calculation
- The deflection compensation control
- The servo and the inverter control mode
- Advanced Y axis control algorithm, can control closed loop valve, also can open loop control valve
- The USB interface



160T/4000  
DA58T



### DA66T

- 2D graphical touch screen programming mode
- 3D visualisation in simulation and production
- 17" high resolution colour TFT, Full Windows application suite
- Delem Modusys compatibility (module scalability and adaptivity)
- USB, peripheral interfacing
- User specific application support within the controllers multitasking environment
- Sensor bending & correction interface



100T/3200  
DA66T



### CybTouch12

- 12 "color LCD display, touch screen, icon recognition function;
- Automatically calculate bending angle, main pressure and deflection compensation;
- Automatic calculation of bending data;
- Automatic calculation of pressure and deflection compensation;
- Automatic calculation of upper die depth;
- Angle, rear gear correction, 2D graphics programming;
- Automatically simulate the bending sequence (option).



160T/3200  
CybTouch12



### ESA-S630

- High-definition 10-inch TFT color touch screen
- Built-in PLC 2D graphics programming
- Expand length calculation
- Graphic upper and lower mold, support the multilateral mold, telescopic mold, arc mold, gooseneck mold and so on
- Graphical programming Automatic, manual optimization
- Supports analog bending
- Support for graphic or numerical arc bending
- support double-click linkage function, no need to purchase another synchronization card



160T/3200  
ESA-S630



### ESA-S640

- High definition 15 inch TFT color display
- Built-in PLC, 2D graphics programming, Calculation of expansion length
- Graphic up and down mold, support multilateral mold, telescopic mold, arc mold, gooseneck mold, etc
- Automatic and manual optimization of graphic programming
- Support simulated bending, Support graphic or numerical arc bending
- PS2 keyboard and mouse interface
- Support dual linkage function, no need to buy synchronous card



## CNC System Brand Description

- DELEM:** DA53T, DA58T, DA66T
- ESA:** ESA S630, ESA S640
- CYBELEC:** CT12, MODEVA12S



**Parameters of CNC Press Brake**



CNC PRESS BRAKE

Model (DMB)	63T/2500	100T/3200	125T/3200	160T/3200	200T/3200	250T/3200	300T/3200	400T/4000	500T/6000	600T/6000	800T/6000	800T/8000	1000T/6000	1000T/8000	1000T/10000
Normal Force (KN)	630	1000	1250	1600	2000	2500	3000	4000	5000	6000	8000	8000	10000	10000	10000
Bending Length (mm)	2500	3200	3200	3200	3200	3200	3200	4000	5000	6000	6000	8000	6000	8000	10000
Vertical Distance (mm)	2000	2700	2700	2700	2700	2700	2700	3100	4900	4900	4200	6200	4200	6200	8200
Throat Depth (mm)	400	400	400	400	400	400	400	400	500	500	600	600	600	600	600
Stroke (mm)	150	200	200	200	200	200	300	300	300	300	400	400	400	400	400
Max. Opening (mm)	380	420	420	420	420	420	500	600	600	600	800	800	800	800	800
Main Power (KW)	5.5	7.5	11	11	15	15	22	30	37	45	55	55	2X37	2X37	2X37
Axes	3+1(Y1, Y2, X, V)														
Compensation	(Hydraulic Compensation)							(Motorized Compensation)							
X-travel (mm)	500							800							
X-speed	200mm/s														
Overall Length (mm)	3100	3500	3500	3500	3500	3500	3500	4500	6500	6500	6500	8500	6500	8500	10500
Overall Width (mm)	1450	1580	1580	1650	1680	1700	1800	2450	2810	2910	2950	2950	3000	3000	3000
Overall Height (mm)	2300	2500	2500	2600	2700	2760	2900	3500	4500	5100	5300	5900	5600	6100	5850
Apprx. Weight (Ton)	5.8	8.5	9.5	11	14	15.5	16.8	31	53	68	90	120	100	130	150



CNC PRESS BRAKE

**Technical Parameters**

Model (DMB)	1200T/6000	1200T/7000	1600T/6000	1600T/7000	1600T/8000	1600T/10000	2000T/8000	2000T/10000	2000T/12000	2000T/14000	3000T/8000	3000T/10000	3000T/12000	3000T/14000
Normal Force (KN)	12000	12000	16000	16000	16000	16000	20000	20000	20000	20000	30000	30000	30000	30000
Bending Length (mm)	6000	7000	6000	7000	8000	10000	8000	10000	12000	14000	8000	10000	12000	14000
Vertical Distance (mm)	4200	5200	4200	5200	6200	8200	5050	7050	9050	11050	6200	8000	9050	11000
Throat Depth (mm)	700	700	700	700	700	700	700	700	700	700	700	700	700	700
Stroke (mm)	400	400	400	400	400	400	500	500	500	500	400	400	400	400
Max. Opening (mm)	800	800	800	800	800	800	900	900	900	900	800	800	800	800
Main Power (KW)	2X45	2X45	2X55	2X55	2X55	2X55	2X75	2X75	2X75	2X75	2X55	2X55	2X55	2X55
Axes	3+1(Y1, Y2, X, V)													
Compensation	(Motorized Compensation)													
X-travel (mm)	1000													
X-speed	200mm/s													
Overall Length (mm)	6500	8500	6500	7200	8500	10500	8500	10500	12500	14500	8500	10500	12500	14500
Overall Width (mm)	3100	3100	3300	3300	3300	3300	3500	3500	3500	3500	3700	3700	3700	3700
Overall Height (mm)	5850	7150	6500	7000	8000	8000	8000	8300	8300	8300	8600	8600	8600	8600
Apprx. Weight (Ton)	130	150	150	170	190	210	260	290	320	350	/	/	/	/

Parameters change without notice. All the above models are suitable for tandem.



## DMS Series CNC/NC Hydraulic Guillotine Shearing Machine



Model	Cutting Thickness	Cutting Length	Angle Range	Backgauge Stroke	Approx. Weight	Overall Length	Overall Width	Overall Height	Main Power
TYPE	(mm)	(mm)	(°)	(mm)	(T)	(mm)	(mm)	(mm)	(Kw)
6x2500	6	2500	1-3	750	4.2	3140	1740	2040	7.5
6x3200	6	3200	1-3	750	5.7	3750	1770	2150	7.5
6x4000	6	4000	1-3	750	8.5	4830	1840	2150	11
6x5000	6	5000	1-3	750	11	5830	1840	2150	11
6x6000	6	6000	1-3	750	14	6480	2100	2300	11
8x2500	8	2500	1-3	750	4.4	3040	1700	1700	11
8x3200	8	3200	1-3	750	6	3860	1700	1700	11
8x4000	8	4000	1-3	750	8.9	4640	1700	1700	11
8x5000	8	5000	1-3	750	11.5	5400	2400	2000	11
8x6000	8	6000	1-3	750	16	6480	2100	2350	11
8x8000	8	8000	1-3	750	29.5	8580	2130	2350	11
10x2500	10	2500	1-3	750	6.5	3040	1800	1700	15
10x3200	10	3200	1-3	750	8	3850	1830	1900	15
10x4000	10	4000	1-3	750	12	4650	2100	2000	15
10x5000	10	5000	1-3	750	16	5750	2100	2000	15
10x6000	10	6000	1-3	750	24	6500	2100	2300	15
10x8000	10	8000	1-3	750	32	6800	2100	2300	15
13x2500	12	2500	1-3	750	8.5	3285	1830	2390	15
13x3200	12	3200	1-3	750	10	3855	1830	2390	18.5
13x4000	12	4000	1-3	1000	13.5	4850	1830	2390	18.5
13x6000	12	6000	1-3	1000	26	6850	1930	2650	18.5
13x8000	12	8000	1-3	1000	46	8950	2130	2850	18.5
13x9000	12	9000	1-3	1000	65	9980	2300	2950	18.5
13x10000	12	10000	1-3	1000	85	11050	2500	3100	18.5
16x2500	16	2500	1-3	1000	13	3440	1940	2830	22
16x3200	16	3200	1-3	1000	15	4010	1940	2830	22
16x4000	16	4000	1-3	1000	16.5	5010	1980	2830	22
16x5000	16	5000	1-3.5	1000	25	5900	2600	2830	22
16x6000	16	6000	1-3.5	1000	31	6900	2700	2830	22
16x8000	16	8000	1-3.5	1000	75	8900	2900	3430	22
20x2500	20	2500	1-3.5	1000	17	3440	1980	2830	30
20x3200	20	3200	1-3.5	1000	20	4010	1900	2830	30
20x4000	20	4000	1-3.5	1000	22	4850	2600	2900	30
20x6000	20	6000	1-3.5	1000	50	6700	3000	3000	30
30x2500	30	2500	1-3.5	1000	29	3440	1900	2830	37
30x3200	30	3200	1-3.5	1000	38	4200	1900	3000	37
40x2500	40	2500	1-3.5	1000	38	3440	2000	3000	37

Parameters change without notice. All the sizes above models are suitable for tandem.

### Standard Equipment



Former Workbench



German BOSCH Hydraulics



USA FIRST Valve Group

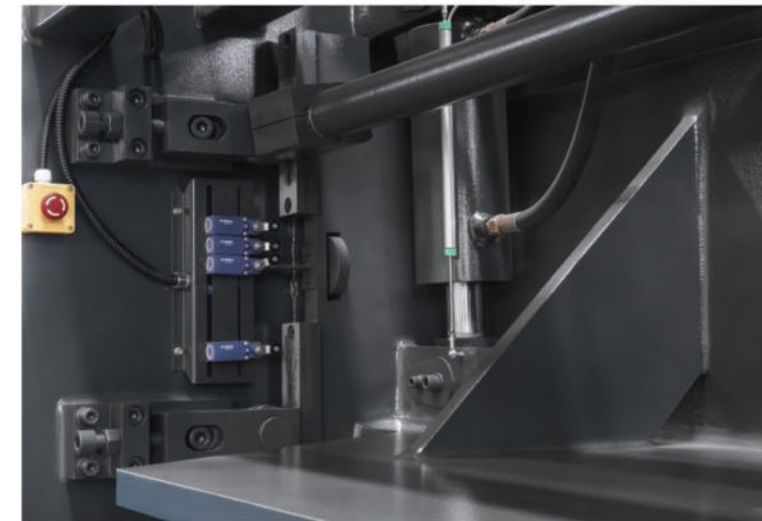

Adjust Blade Clearance With Upper Fulcrum



Electric Adjustment of Blade Clearance



Servo Motor

### Optional Equipment

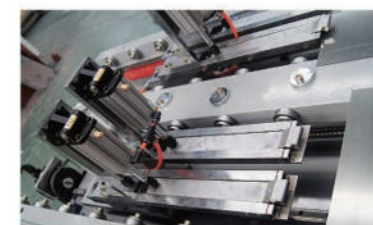

Precision Front Feeding



Belt Conveyor



Pneumatic Backgauge Support  
(ball bearing slide plate)



## CNC/NC Hydraulic Guillotine Shearing Machine

### Controller



#### E21S

- LCD high-definition display.
- Control backline shaft (X).
- Automatic fast movement and low speed positioning.
- Independent manual movement function in X-axis.
- Cut counting function.
- Set the scale factor freely.
- Multi-step programming, program automatic running, continuous positioning.
- Power off memory stoppers and stops of positions, programs, parameters.
- Automatic back-off function to avoid interference between backliner and workpiece.
- Unidirectional positioning function eliminates screw drive clearance.
- Metric/imperial conversion function.
- Hardware diagnostic functions.
- High-quality, tactile keys.



#### DAC360T

- Panel mounting
- Bright LCD display
- Rear/front stopper control
- Back-off function
- Shear angle and gap control
- Cut stroke limit
- All axes can be moved manually
- Pressure control
- Plate thickness detection
- Return to feeding position function
- Second and third servo axis control
- Sheet metal support function

### Main Features:

Bright LCD screen, Backgauge control, Retract function, Cutting angle control, Cutting gap control, Stroke length limitation, Force control, Manual movement of axes;

### Optional Controllers:

ESTUN E21S, E200PS, DAC360T, DAC362T, CT8G

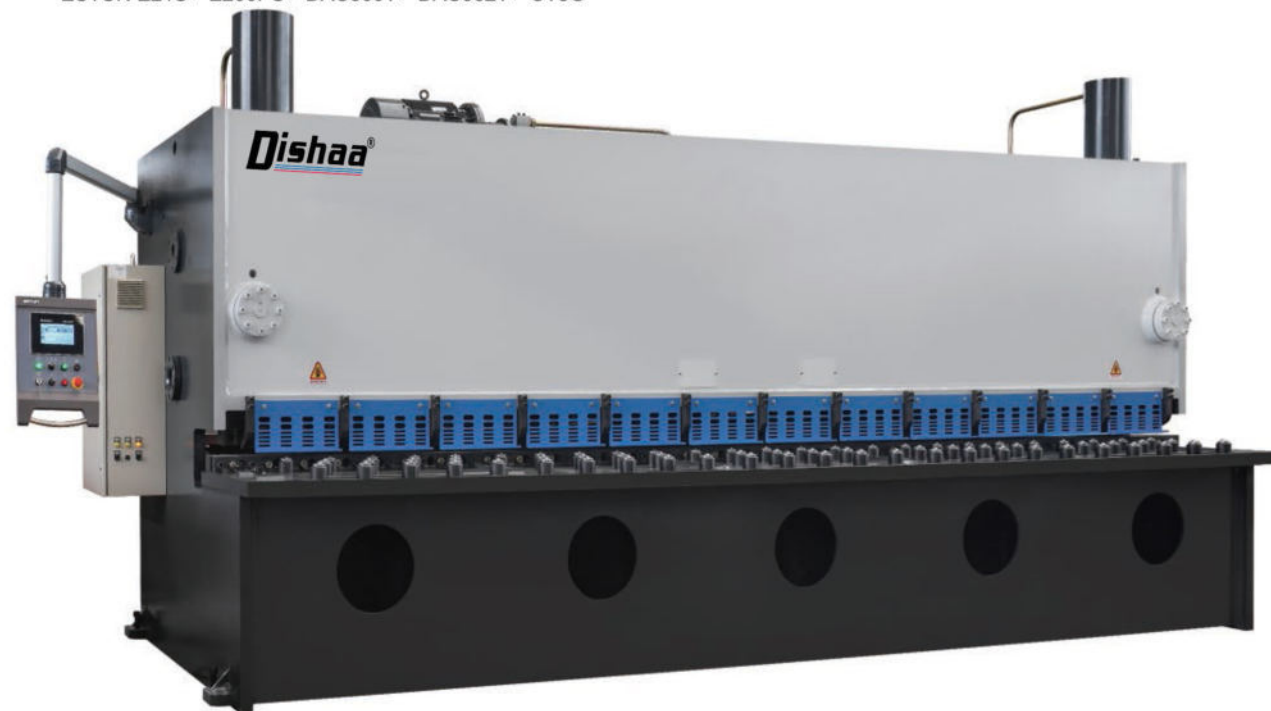

## NC Hydraulic Swing Beam Shearing Machine

### ( E21S )

The UG (finite element) analysis method was used to optimize the design with computer aid. The fuselage adopts integral steel plate welded structure, which has good strength, rigidity and vibration resistance. Internal stress relief by tempering. The whole frame is sanded to remove rust and sprayed with anti-rust paint. The table is equipped with an auxiliary tool holder for easy blade adjustment. The work surface is equipped with feeding balls, which is light to operate. The blade gap adjustment adopts stepless adjustment mechanism to adapt to the shearing needs of different plate thicknesses and materials. Rectangular lower blade with four cutting edges for extended blade life. Adjust the shear stroke to improve processing efficiency and realize segmented shearing function. The number of cuts is automatically counted, which reduces the inventory work of cumbersome locks.

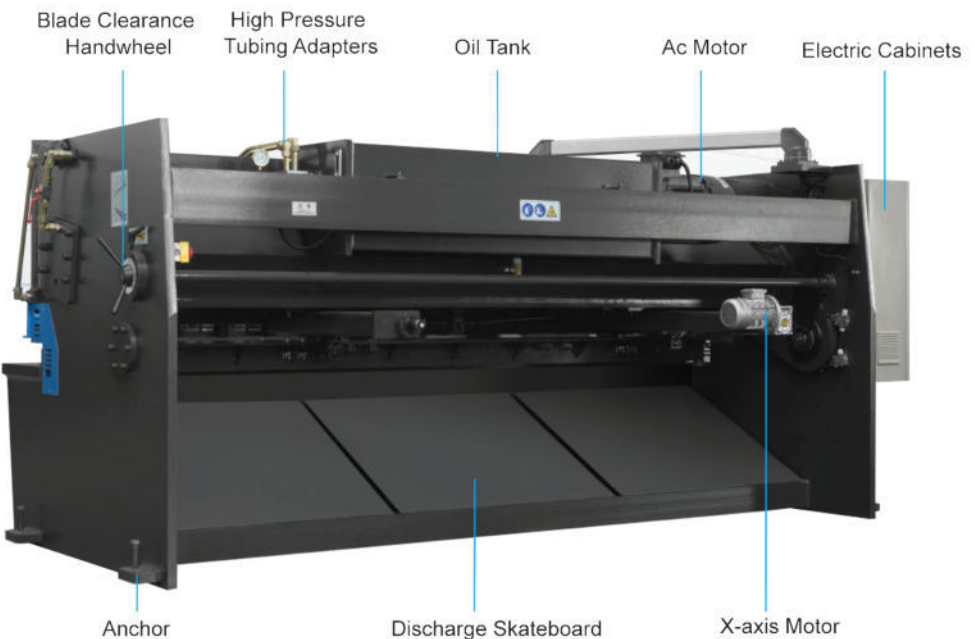



## Controller



### E21S

- LCD high-definition display.
- Control backline shaft (X).
- Automatic fast movement and low speed positioning.
- Independent manual movement function in X-axis.
- Cut counting function.
- Set the scale factor freely.
- Multi-step programming, program automatic running, continuous positioning.
- Power off memory stoppers and stops of positions,

- programs, parameters.
- Automatic back-off function to avoid interference between backliner and workpiece.
- Unidirectional positioning function eliminates screw drive clearance.
- Metric/imperial conversion function.
- Hardware diagnostic functions.
- High-quality, tactile keys.



### DAC360T

- Panel mounting
- Bright LCD display
- Rear/front stopper control
- Back-off function
- Shear angle and gap control
- Cut stroke limit
- All axes can be moved manually
- Pressure control
- Plate thickness detection
- Return to feeding position function
- Second and third servo axis control
- Sheet metal support function

### Delem | Integrated touchscreen

The bright LCD display and easy-to-operate touch screen make it very convenient for users to operate. The operator relies on clear icons to easily complete all functions of data programming.

The DAC-362T supports two and three stopper shaft controls, providing control of additional stoppers and related functions. All pressures of clamping and shearing can be effectively controlled on the DAC-360T.



Brand Main Motor And Oil Pump



Pendulum Tool Holder Structure



Rexroth Hydraulic Valves



Blade Clearance Adjustment Handwheel



X-axis Ball Screw And Grinding Light Rod



X-axis Drive Motor



Position The Ruler In Front Of The Workbench



Backgauge Servo Motor



Ball Screws And Linear Guides

Model	Thickness (Mm)	Width (Mm)	Cutting Angle (°)	Material Strength (Kn/cm)	Backgear Travel (Mm)	Cutting Times (T/min)	Power (Kw)	Weight (T)	Overall Dimension L×w×h(Mm)
4×2500	4	2500	1°30'	≤450	20-600	16	5.5	3.4	3100×1700×1650
4×3200	4	3200	1°30'	≤450	20-600	14	5.5	4	3800×1700×1650
4×4000	4	4000	1°30'	≤450	20-600	10	5.5	5.6	4600×1750×1750
6×2500	6	2500	1°30'	≤450	20-600	14	7.5	4.4	3100×1750×1700
6×3200	6	3200	1°30'	≤450	20-600	12	7.5	5.1	3800×1750×1700
6×4000	6	4000	1°30'	≤450	20-600	8	7.5	7.6	4600×1850×1850
6×5000	6	5000	1°30'	≤450	20-600	6	11	12.5	5600×2050×2180
6×6000	6	6000	1°30'	≤450	20-600	5	11	14.8	6600×2120×2230
8×2500	8	2500	1°30'	≤450	20-600	10	11	5.3	3100×1750×1700
8×3200	8	3200	1°30'	≤450	20-600	8	11	6.5	3800×1750×1700
8×4000	8	4000	1°30'	≤450	20-600	8	11	7.7	4600×1850×1850
8×5000	8	5000	1°30'	≤450	20-600	8	11	13.5	5600×2100×2230
8×6000	8	6000	1°30'	≤450	20-600	8	11	15.8	6600×2200×2300
10×2500	10	2500	2°	≤450	20-600	9	11	6.5	3100×2820×1920
10×3200	10	3200	2°	≤450	20-600	9	11	7.7	3800×1820×1920
10×4000	10	4000	2°	≤450	20-600	8	11	9	4600×1900×2000
10×6000	10	6000	2°	≤450	20-750	5	15	22	6600×2400×2350
12×2500	12	2500	2°	≤450	20-600	9	18.5	8	3100×1850×2020
12×3200	12	3200	2°	≤450	20-600	9	18.5	9.4	3800×1820×1920
12×4000	12	4000	2°	≤450	20-600	8	18.5	11.8	4600×1950×2100
12×5000	12	5000	2°	≤450	20-750	6	18.5	21	5600×2400×2350
12×6000	12	6000	2°	≤450	20-750	5	18.5	26	6600×2400×2350
16×2500	16	2500	2°30'	≤450	20-600	9	22	9.2	3100×1950×2080
16×3200	16	3200	2°30'	≤450	20-600	8	22	10.6	3800×1950×2080
16×4000	16	4000	2°30'	≤450	20-600	8	22	15.3	4600×2300×2180



## DMD Series Double-Drive High Speed Fiber Laser Cutting Machine



### Performance

DMD series fiber laser cutting machine has many unique advantages in laser cutting applications. Excellent beam quality, suitable for high-speed and high-precision cutting. Small size, higher integration. The laser output power is stable and the equipment reliability is high. High efficiency, low energy consumption and low cost. Good dynamic characteristics and high efficiency.

### Sample Display

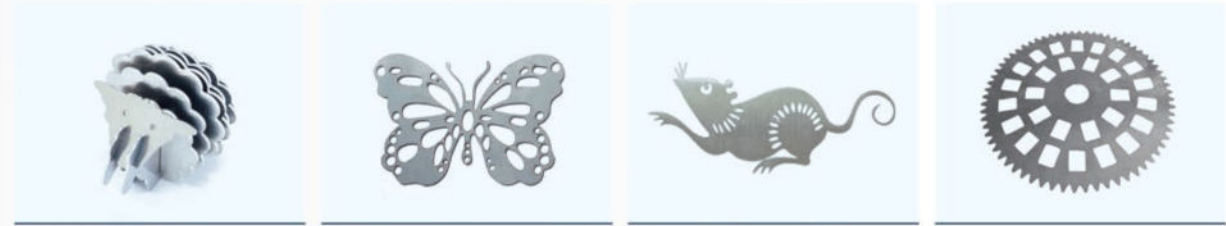

### Tubesheet Welded

- The bed adopts tube plate combined with welding structure (Internal aircraft metal honeycomb structure, mortise and tenon structure welding)
- It has higher rigidity, torsion resistance and deformation resistance
- The unique structure design has the ability to resist the deformation caused by high cutting heat
- Stress relief annealing after welding to ensure no deformation of the bed after 20 years of use

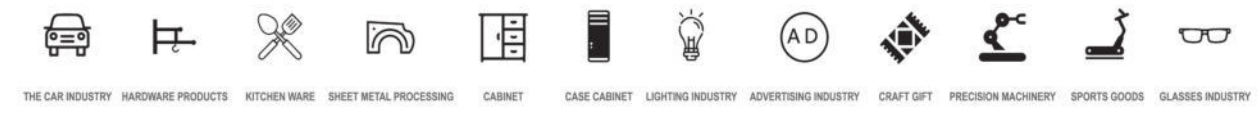

Model	DMD-3015	DMD-4015	DMD-4020	DMD-6020	DMD-6025	DMD-8025
Cutting Range	3000*1500mm	4000*1500mm	4000*2000mm	6000*2000mm	6000*2500mm	8000*2500mm
Laser Power	< 3000W	< 3000W	< 6000W	< 12000W	< 12000W	< 12000W
Max. Positioning Acceleration	10m/s <sup>2</sup>	10m/s <sup>2</sup>	10m/s <sup>2</sup>	10m/s <sup>2</sup>	10m/s <sup>2</sup>	10m/s <sup>2</sup>
Positioning Accuracy	±0.02mm/m	±0.02mm/m	±0.02mm/m	±0.02mm/m	±0.02mm/m	±0.02mm/m
Reposition Accuracy	±0.03mm	±0.03mm	±0.03mm	±0.03mm	±0.03mm	±0.03mm

\*The displayed parameters are for reference only, the actual parameter information is subject to the actual product



## DMP Series Exchange Worktable Fiber Laser Cutting Machine



### Performance

The new closed design, double table fast exchange, while processing edge cutting, fast, small slit, smooth section, easy operation, low energy consumption, suitable for large quantities of continuous processing, highlighting cutting competitive advantage.

### Sample Display



### Brand Laser Head

- Without manual focusing, the software can automatically adjust the focus lens and control the height of the upper and lower parts, so as to realize the automatic piercing and cutting of plates with different thickness. The software can memorize the focal length of different plates, and the operation is simpler, which is ten times of the manual speed.
- The precision is 0.01mm, which is suitable for different types of plates from 0 to 20 mm.
- Double water cooling of collimating lens and focusing lens reduces the temperature of cutting head and improves the service life of cutting head.



Model	DMP-3015	DMP-4020	DMP-6020	DMP-6025	DMP-8025
Cutting Range	3000*1500mm	4000*2000mm	6000*2000mm	6000*2500mm	8000*2500mm
Laser Power	< 20000W	< 20000W	< 20000W	3000-20000W	3000-20000W
Max. Positioning Acceleration	20m/s <sup>2</sup>	20m/s <sup>2</sup>	20m/s <sup>2</sup>	20m/s <sup>2</sup>	20m/s <sup>2</sup>
Positioning Accuracy	± 0.02mm/m	± 0.02mm/m	± 0.02mm/m	± 0.02mm/m	± 0.02mm/m
Reposition Accuracy	± 0.03mm	± 0.03mm	± 0.03mm	± 0.03mm	± 0.03mm

\*The displayed parameters are for reference only, the actual parameter information is subject to the actual product.



## DMDR Series Plate And Tube Integration Laser Cutting Machine

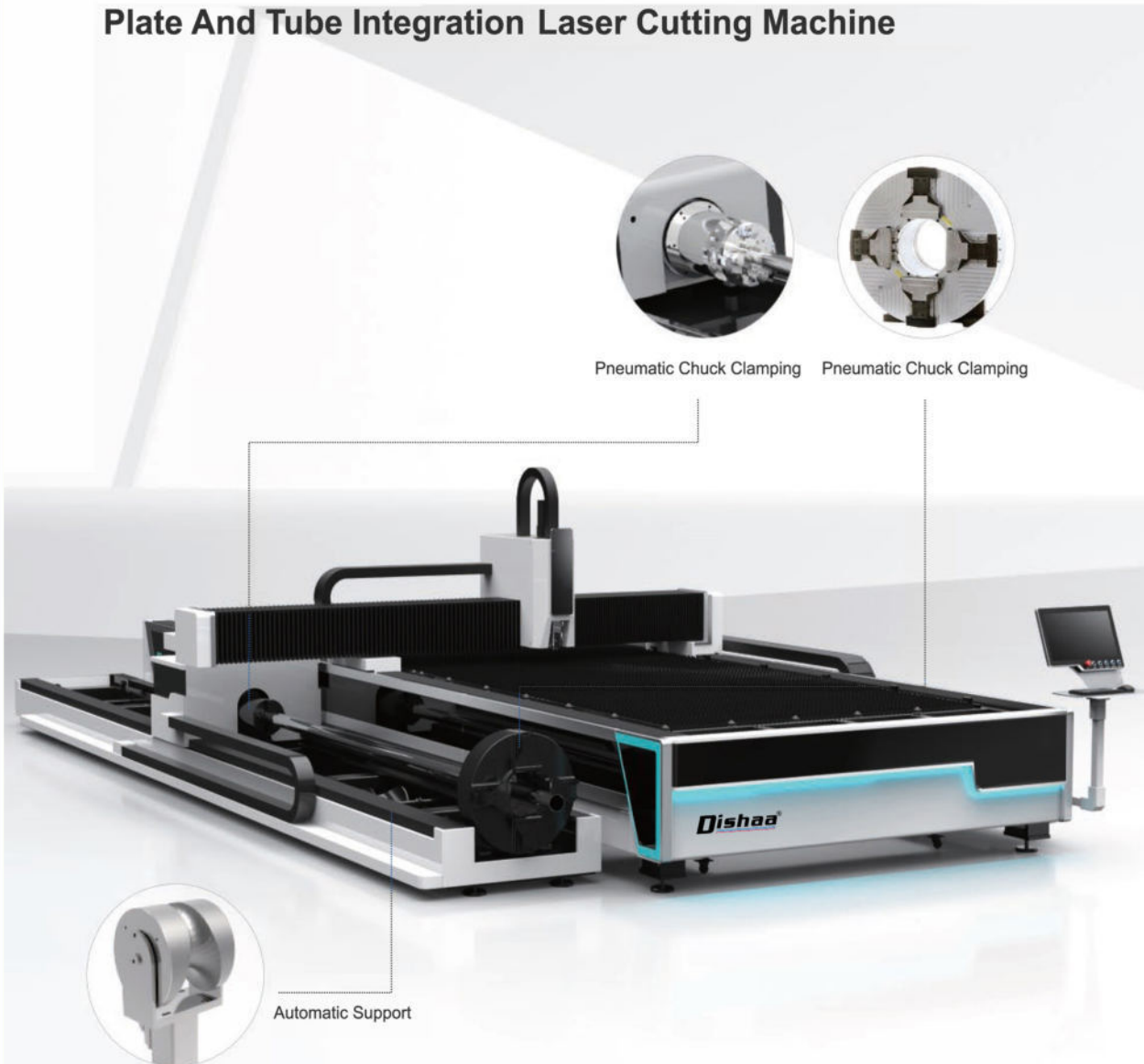

### Performance

Tube sheet integrated cutting, easy to exchange, can not only cut flat plate, but also meet the needs of users to cut round tube, square tube and forming box.

- It can cut multiple intersecting line holes with different directions and diameters on the main pipe
- It can cut the oblique section end face at the end of the pipe
- It can cut the intersection line end of branch pipe intersecting with annular main pipe
- It can cut square hole, waist hole and round hole on round pipe

The steel pipe can be cut off

- It can cut various graphics on the surface of square pipe
- It can cut steel plates of different specifications
- It can cut and cut holes on the forming box

### Sample Display



### Brand Laser

- Fiber laser adopts air-cooled compact structure design, semiconductor fiber as laser generation medium, green environmental protection, simple mechanical structure, constant optical path, basically maintenance free, stable cutting performance.



Model	DMDR-3015	DMDR-4020	DMDR-6020	DMDR-6020
Cutting Range	3000*1500mm	4000*2000mm	6000*2000mm	6000*2500mm
Pipe Cutting Length	6000mm	6000mm	6000mm	6000mm
Chuck Diameter	220/320mm	220/320mm	220/320mm	220/320mm
Laser Power	< 6000W	< 6000W	< 6000W	< 6000W
Max. Positioning Acceleration	10m/s <sup>2</sup>	10m/s <sup>2</sup>	10m/s <sup>2</sup>	10m/s <sup>2</sup>
Positioning Accuracy	± 0.02mm/m	± 0.02mm/m	± 0.02mm/m	± 0.02mm/m
Reposition Accuracy	± 0.03mm	± 0.03mm	± 0.03mm	± 0.03mm

\*The displayed parameters are for reference only, the actual parameter information is subject to the actual product



## DMPR Series



### Professional Laser Cutting Control System

It adopts "CypCut plane cutting software", which is a set of software specially developed for the laser cutting industry. It is easy to use and has rich functions, which is suitable for various processing occasions. It can quickly set lead, micro-connection, compensation and other processes. With the batch modification function, it can quickly complete the setting of the whole board process. It supports floating coordinate system and workpiece coordinate system, supports photoelectric edge finding and capacitive edge finding, and quickly corrects the board. deviation angle.



#### Technical Parameters

Project	Unit	DMPR-3015	DMPR-4020	DMPR-6020	DMPR-6025	DMPR-8025
Sheet Cutting Range	mm	3000*1500	4000*2000	6000*2000	6000*2500	8000*2500
Laser Power	W	≤10000W	≤30000W	≤30000W	≤30000W	≤30000W
Tube Length	mm	6000~12000	6000~12000	6000~12000	6000~12000	6000~12000
Cut Pipe Diameter	mm	200~360	200~360	200~360	200~360	200~360
Acceleration	m/s <sup>2</sup>	20	20	20	20	20
Positioning Accuracy	mm/m	±0.02	±0.02	±0.02	±0.02	±0.02
Repeatability	mm	±0.03	±0.03	±0.03	±0.03	±0.03

\*The displayed parameters are for reference only, the actual parameter information is subject to the actual product

### Laser Cutting System Shared By Plate and Tube

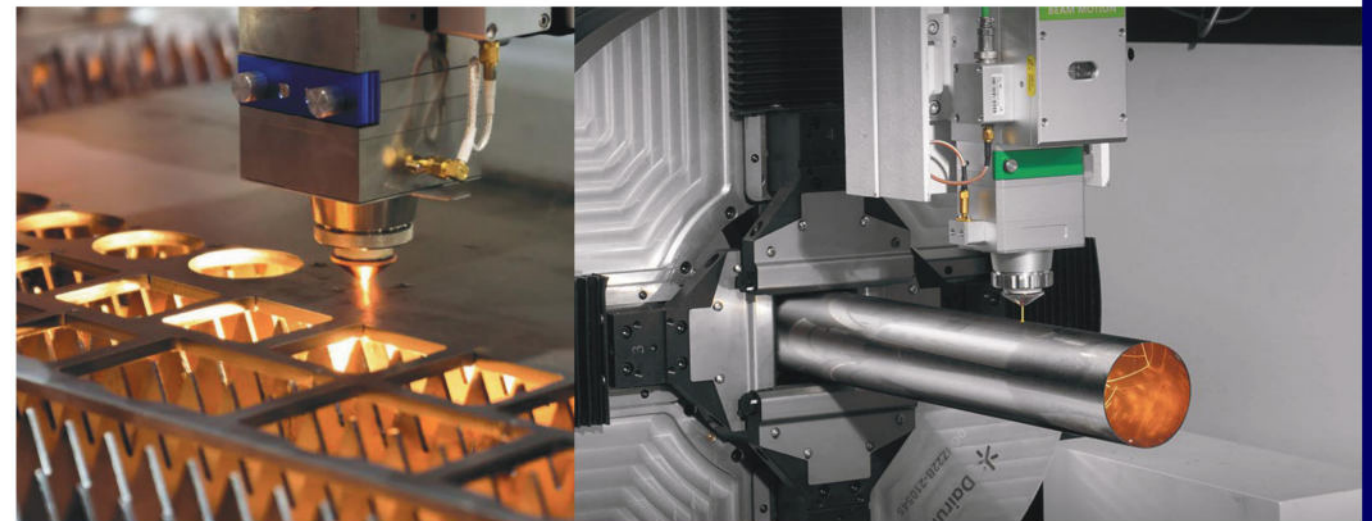

### Laser Cutting Head



Optimized optical configuration and smooth and efficient airflow design, Significantly improve cutting quality and efficiency;  
Automatic focusing, reducing human intervention, focusing accuracy of 0.05mm;  
Collimation adds protective lenses to effectively protect the collimating lenses;  
Quick and easy replacement of protective lenses;



## Tube Clamping Rotary Chuck



### Chuck

- ① Automatic centering of the chuck, automatic clamping, no need to replace the jaws for the full stroke
- ② The moment of inertia of the chuck is small, and the positioning accuracy is high
- ③ The chuck has high precision for repeated card loading

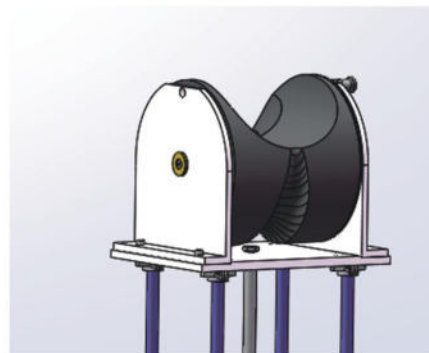
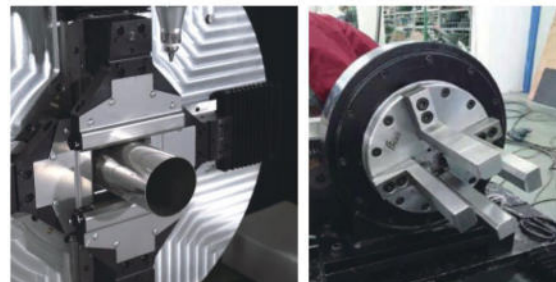

### Variable Diameter Support System

The system is equipped with multiple lifting support mechanisms with rotatable pipe diameters. And realize the function of automatic lifting and changing diameter

## Equipment Main Configuration List

No.	Project	Configure Content Or Description	Place of Origin
1	Machine Tool System: Gantry Double Drive Structure	Rack And Pinion	Taiwan YYC
		Reducer	French Motoreducer
		Beam Structure	DISHAA
		Motor System	Fuji, Japan
		Guide	Taiwan HIWIN/Japan SMG
2	Laser Generator	Maxphotonics Fiber Laser	China
3	Cooling System	Laser Supporting Water Cooling System	China
4	Cutting Head System	Raytools	China Raytools
5	Workbench Form	Fixed Workbench	DISHAA
6	Sheet Metal Form	Half-enclosed Sheet Metal Housing	DISHAA
7	Control System	BoChu	ShangHai
8	Exhaust System	Large Flow Fan	China
9	Gas Distribution System	Throttle Valve, Pressure Reducing Valve, Electric Proportional Valve	Japan, etc.
10	Computer	Dual-core Cpu 2.6ghz + Memory 1g + Hard Disk 250g + 19-inch Screen	Industrial Computer
11	The Composition Of The Cutting Head System	Optical Fiber Cutting Head Lens	Optical fiber dedicated
		Capacitive Sensor + Amplifier (Built-in) + Adjustment Box	China
12	Electrical System Composition	Contactors, Air Switches, Etc.	Schneider
		Photoelectric Switch, Etc.	Omron
		Terminal	Weidmüller, Germany
		Tanks Chain	China
13	Appendix	Protective Lens + Single And Double Layer Nozzle + Ceramic Ring + Nozzle Connecting Line	DISHAA



## CO2 Laser Marking Machine with RF Metal Tube



### Equipment Advantages

1. It adopts imported or high-quality domestic CO2 RF laser source, which has better beam quality, high photoelectric conversion rate and good performance.
2. High engraving precision, clear marking machine, not easy to wear, fast marking speed, stable performance, no consumables for equipment.
3. Long working life, stable laser output, suitable for industrial long term continuous work, and can be refilled with gas continuing to use.
4. Support PLT, PCX, DXF, BMP and other documents, directly use SHX, TTF fonts, support automatic coding, serial number, batch number, date, barcode and QR code marking, software has graphic anti-play function.

### Technical Parameters

Model	DX-30S	DX-60S	DX-100S
Laser power	30W	60W	100W
Laser wavelength	10.64um	10.64um	10.64um
Repeat frequency	≤20KHz	≤20KHz	≤20KHz
Marking speed	≤7000mm/s	≤7000mm/s	≤7000mm/s
Minimum font	+/-0.4mm	+/-0.4mm	+/-0.4mm
Repeat positioning accuracy	±0.01mm	±0.01mm	±0.01mm
Control system	Internal air cooling or outer water cooling	Internal air cooling or outer water cooling	Internal air cooling or outer water cooling
Power supply	AC 110V/220V ±10%,50HZ	AC 110V/220V ±10%,50HZ	AC 110V/220V ±10%,50HZ
Whole power	1500W	1500W	1500W

### Sample Display



### Applicable Fields

Popular for non-metal materials marking, widely used in leather, wood, textile, plastic, signage, packaging, crafts, electronics, communications devices, watches, glasses, printing, decoration areas, etc.



## Large Format Dynamic CO2 Laser Marking Machine with RF Metal Tube

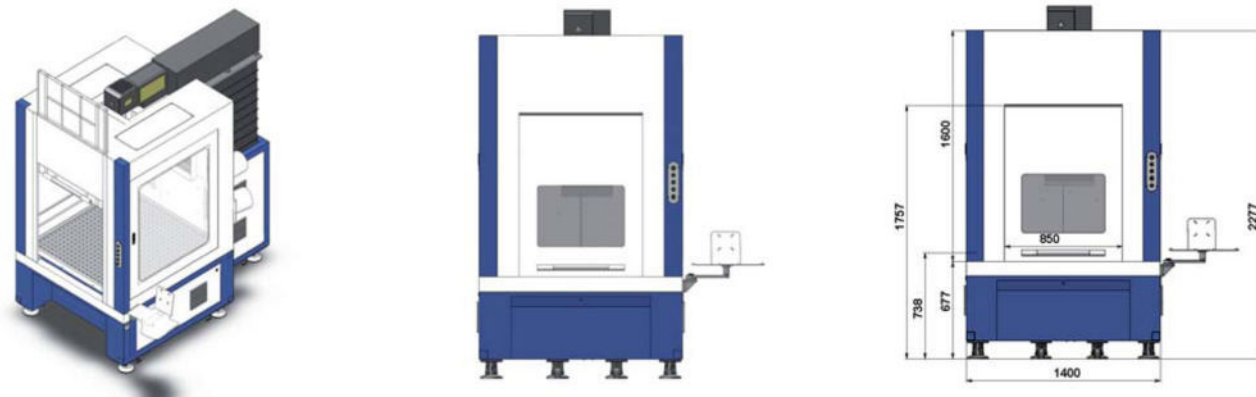

### Equipment Advantages

1. Suitable for large-area engraving marking of various non-metallic materials; layered setting, perfect combination of surface engraving, hollowing and cutting.
2. It can be applied to the cutting of soft and low-density sheets. It has strong laser energy, fine beam and small mechanical stress.
3. Ideal for marking rolled fabrics, marking on jeans to get different marking effects and flying marking.
4. Fully enclosed optical path, imported CO2 RF laser and strict multiple control design.

### Applicable Fields

Ideal for marking rolled fabrics, marking on jeans to get different marking effects and flying marking.

### Technical Parameters

Model	DXF-1212/16110
Process area	1200*1200mm , 1600*1000mm
Laser power	100W-600W optional
Laser wavelength	10640nm
Laser type	RF sealed laser generator imported from US
Lens	Laser conductive lens full set imported from US i
Cooling system	Professional industrial forced water-cooling system
Marking speed	0-7000mm/s
Laser energy control	0-100% software setting
Minimum font	1.8mm
Minimum character space	0.4mm
Positioning accuracy	≤+0.01mm
Control software	Chanxan dynamic control system
Support format	Photoshop,coreldraw,autocad,plt,ai,bmp,dxf,shx,ttf
Auxiliary device	Exhaust fan and exhaust pipe
Power supply	AC 110V/220V ± 10%, 50HZ/60HZ
Working environment	Temperature:1-45℃, Humidity:5-95%
Optional configuration	Honeycomb table or auto feeding system

### Sample Display

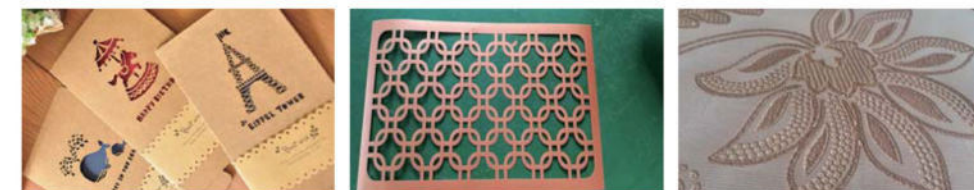



## UV Laser Marking Machine



### Equipment Advantages

1. The heat-affected zone is extremely small, avoiding deformation, damage or charring of the material to be processed and the yield is high.
2. Applied on various materials to make up shortcomings of fiber laser or CO2 laser marking.
3. High photoelectric conversion rate, 355nm output wavelength, beautiful engraving effect, good touch feeling, high anti-counterfeiting effect.
4. Products are widely used in micro-machining, fine engraving of various metal and non-metal film materials.

### Technical Parameters

Model	DX-03Z/08Z/10Z
Process area	100*100mm
Laser power	3W/8W/10W optional
Laser wavelength	355nm
Laser type	808nm semiconductor pumping source
Lens	Laser lens imported from US
Cooling type	Professional industrial thermostat system
Marking speed	500 characters/sec
Laser energy control	0-100% software setting
Minimum font	0.1mm
Minimum mark line-width	0.01mm
Repeat positioning accuracy	±0.001mm
Whole power	1.5KW
Power supply	AC 110V/220V ± 10%,50HZ/60HZ
Working environment	Temperature:1-45℃,Humidity:5-95%
Dimensions	900*1000*1600mm

### Sample Display



### Applicable Fields

Suitable for high-end market for ultra-fine processing such as mobile phones, chargers, data cables and pharmaceutical packages, cosmetics packages and polymer materials surface making. Also it can be used for marking of flexible PCB boards, dicing; micro-holes and blind holes for silicon wafers, LCDQA code marking, glassware punching, metal surface marking, plastic buttons, electronic components, gifts, communication equipment, building materials marking, etc.



## Large Format Laser Marking Machine



### Applicable Fields

It is applied to large format, large-size whole format marking, ruler scale, elevator, sanitary ware, billboard, etc.

### Equipment Advantages

1. Good marking effect. The high-quality laser source guarantees high-quality beam quality, and the marking effect is very delicate.
2. Deep marking. It can meet the needs of deep marking, the deepest can reach 0.5mm (depending on the material) which can meet most of the needs.
3. High marking accuracy: splicing marking accuracy can reach  $\pm 0.005\text{mm}$
4. Long service life. The fiber laser source can reach 100,000 hours, and the machine can be used for 3 to 5 years.
5. No consumables, no pollution, energy saving and environmental protection, compliance with European environmental protection standards.
6. No need to adjust the light path. The optical path system has been debugged before leaving the factory and it is a closed optical path structure without subsequent adjustments.
7. Low cost and low power consumption.

### Technical Parameters

Model	DS-1325
Average output power	100W (Optional)
Marking line speed	$\leq 7000\text{mm/s}$
Marking size	1300*2500mm (Can be customized on demands)
Minimum character height	0.2mm
Marking repeatability	$< 24 \mu\text{rad}$
Marking depth	0.3mm (Depends on the material)
Minimum line width	0.06mm (Depends on the material)
Power supply	AC 220V 50KHz
Motor	Stepper motor/servo motor (optional)
Positioning accuracy	0.05mm
Repeatability	$\pm 0.01 \text{ mm}$
Displacement speed	100~300mm/s

### Sample Display





## Fiber Laser Marking Machine



### Applicable Fields

Popular in electronic components, hardware products, tool accessories, integrated circuits (IC), electrical appliances, mobile phone accessories, precision instruments, glasses and watches, jewelry, car parts, plastic buttons, PVC pipes, medical equipment and other industries for materials like common metals and alloys (iron, copper, aluminum, magnesium, zinc, etc), rare metals and alloys (gold, silver, titanium), metal oxides, special surface treatment (phosphating, aluminum anodizing, Electroplating surfaces, ABS materials, etc).

### Equipment Advantages

1. It has a wide range of applications and can be used to engrave metallic materials and some non-metallic materials.
2. Marks do not fade due to environmental relationships (touch, acid and alkaline gases, high temperatures, low temperatures, etc.) and have high anti-counterfeiting properties.
3. Line widths can be as small as 10cm and depths up to 10cm, marking the surface of parts of the 'mm' size.
4. The marking effect is exquisite, the process is beautiful and the precision is high, which can improve the product grade and enhance the added value of the product.
5. No consumables, no pollution, energy saving and environmental protection in line with European environmental standards; easy to learn, no need for too much labor costs; high efficiency, long life and maintenance-free performance.

### Technical Parameters

Model	DX-30G/50G/100G
Laser power	30W/50W/100W
Laser wavelength	1064nm
Repeat frequency	20-80KHz
Engraver speed	≤ 7000mm/s
Minimum font	+/- 0.15mm
Repeat positioning accuracy	± 0.002mm
Control system	Internal air cooling
Power supply	AC 110V/220V ± 10%, 50HZ
Whole power	500W

### Sample Display





## Laser Cleaning Machine

Laser cleaning equipment is a new generation of high-tech products which can clean the surface of metal material.

Easy to install and operate.

Connect to the power, turn on the equipment, then can clean work pieces without chemical reagents, media, dust and water. The machine can focus automatically, and have the advantages of curved surface cleaning and high cleanliness. It can remove dirt, rust, on the surface of work pieces.

Advantages:

The machine can use same laser source with laser welding machine, change the laser cleaning gun easily and controller to reach cost performance and work performance result, user can buy the machine easily within budget



Laser cleaning machine is mainly used in aviation, ship, cultural relic protection, automobile peripheral, track, weapons, electronics industry, Precision hardware and other fields. Such as: metal surface rust removal; surface oil pollution, stain, dirt cleaning; surface coating, coating removal; welding surface / spray surface pretreatment;

### Technical Parameters

Model	DLW- 1000C / 1500C / 2000C
Output optical power	1000W/1500W/2000W
Large pulse energy	100J
High peak power	9.9kw
Pulse width	0-15ms
Repetition frequency	50-50,000HZ
Spectroscopic methods	Precision energy splitting or high speed time splitting
Closed loop feedback control	Arbitrary waveform rea-time control power negative feedback
Energy fluctuation	< ±3%
Aiming mode	Laser diode red light indication
Numbers of optical fiber paths	standard one light paths
Cooling way	Built-in water chiller
Power consumption of equipment	≤5kw
Power requirements	AC 220V+15%,50HZ/60HZ
Size of host	1360*660*1060mm

### Comparison Cleaning



Before

After



## Laser Welding Machine



### Applicable Fields:-

It is widely used for welding all kinds of stainless steel mirror words, stainless steel brushed words, stainless steel spherical characters, stainless steel paint characters, stainless steel spray words, stainless steel solid words, stainless steel plating word, stainless steel gold foil words, precision stainless steel characters, titanium flat words, titanium spherical surface word, Seiko Titanium, Flat Copper, Spherical Copper, Copper, Copper Antique, Seiko Aluminum, Iron Paint (Stainless Steel, Iron, Low Carbon Steel), metal word welding. Lighting and mould industry, optoelectronic communication devices, medical treatment, electronics, copper, aluminum and small welding processing industries.

### Equipment Advantages:-

1. It is easy to operate, you can get on the job without special job permit, and you can weld beautiful products without skill of the master.
2. The welding speed is 2-10 times faster than the traditional welding. One machine can save at least 2 welders a year.
3. The weld seam is smooth, reducing the subsequent grinding process, saving time and cost.
4. Welding large metal advertising characters use hand-held welding heads to overcome the limitations of the work space.
5. The fixed welding head can rotate in all direction to overcome the inconvenience of the traditional welding head in one direction.
6. Suitable for all kinds of complex welds, spot welding of various devices.

### Technical Parameters

Model	DW-1000/1500/2000
Laser wavelength	1064nm
Output optical power	1000W/1500W/2000W
Large pulse energy	100J
High peak power	9.9kw
Pulse width	0-15ms
Repetition frequency	0-150HZ
Spectroscopic methods	Precision energy splitting or high speed time splitting
Closed loop feedback control	Arbitrary waveform real-time control power negative feedback
Energy fluctuation	<±3%
Aiming mode	Laser diode red light indication (CCD option)
Number of optical fiber paths	(standard one light path)
Cooling way	Built-in water chiller
Power consumption of equipment	4KW
Power requirements	AC220V±15% 50/60HZ
Size of the host	1360x660x1060mm (length, width and height)

### Sample Display





## CNC cutting Machine

CNC Table Type Plasma Cutting Machine



### Technical Specifications

Model	DMTC-1530
Effective cutting area	1500*3000mm (4.9*9.8 ft)
Cutting mode	Plasma oxy-fuel(Optional)
Plasma cutting thickness	Depends on plasma source
Oxy-fuel cutting thickness	5mm—50mm (1/5—2 inch)
Drive system	Dual drive, stepper motors/servo motors
CNC system	Fangling CNC controller
Torch height control	Arc voltage auto THC and anti-collision for plasma cutting
Running speed regulation range	0—12000 mm/min
Workable option	Water workable

### Spare Parts



Plasma Power Sources

CNC Gantry Type Plasma Cutting Machine

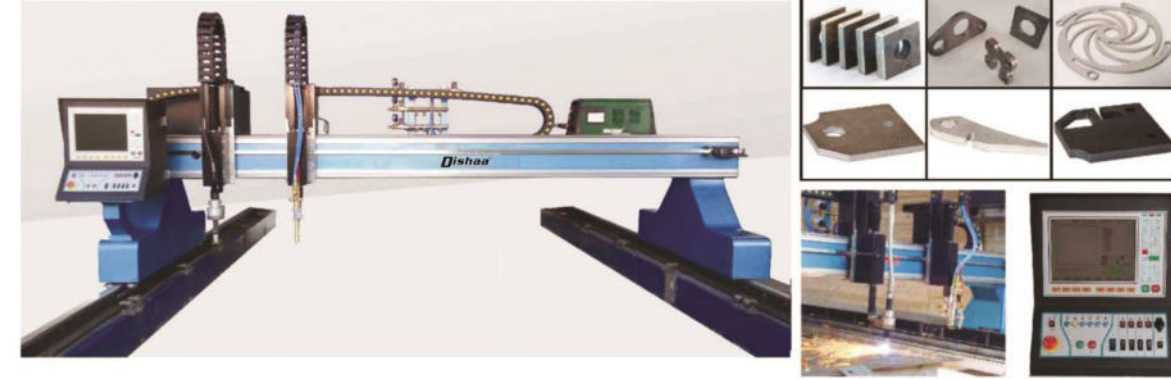

### Technical Specifications

Model	DMSC-3000/4000
Track span	3000mm/4000mm
Effective cutting width	2300mm—3300 (7.5ft—10.8ft)
Effective cutting length	Standard 4500mm, can be extended per 2000mm
Cutting mode	Plasma, oxy-fuel or plasma+oxy-fuel
Torch height control	Arc voltage auto THC and anti-collision for plasma cutting

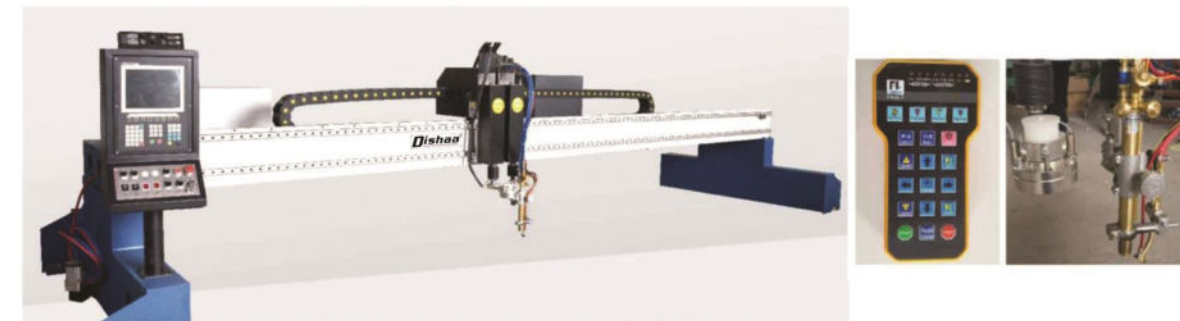

### Technical Specifications

Model	DMGC-4000/5000/6000/8000
Track span	4000/5000/6000/8000mm
Working width	3300/4300/5300/7300mm (10.8ft/14.1ft/17.3ft/23.9ft)
Working length	Depends on customer's requirement
Cutting mode	Plasma, oxy-fuel or plasma+oxy-fuel
Cutting thickness	2--200mm (1/10—7inches)
Drive system	Dual drive, servo motors
CNC system	Hyperthem/ Fangling CNC
Torch height control	Arc voltage auto THC and anti-collision for plasma cutting
Cutting speed	0-10000mm/min
Optional functions	Capacitance auto THC for oxy-fuel cutting, auto ignition for oxy-fuel cutting, underwater plasma cutting, power marking, bevel cutting, laser position, chair, different color



## CNC 4-Roller Plate Rolling Machine



### Advantages

1. Hydraulic-driven, high efficiency (driving power equivalent 60% traditional);
2. Permanent lubrication technology (bearing life period without refueling);
3. Clamping pressure is adjustable (non-existent skidding, productivity is 50-80% than three roller plate rolling clamping);
4. Rolling diameter can catch 1.1 times of the top roller;
5. It can meet many kinds of demands

### Following users apply to use the machine:

1. Operators to lack of experience and require high efficiency;
2. Require high accuracy to improve products quality;
3. Only need one operator to reduce labor costs;
4. Require conveying device, feeding device and support device because of large size plate or high productivity or security;
5. Require CNC operation to reduce errors caused by human factors.



### Technical Parameters

Specifications & models	Max. Pre-rolling thickness (mm)	Max. Rolling thickness (mm)	Diameter of upper roller (mm)	Plate width (mm)	Main motor power (kw)
DW12-3X1500	2	3	135	1500	2.2
DW12-5X1500	3	5	190	1500	4
DW12-10X2000	8	10	240	2000	11
DW12-10X2500	8	10	260	2500	15
DW12-12X2000	10	12	260	2000	15
DW12-15X2000	12	15	265	2000	18.5
DW12-15X2500	12	15	280	2500	22
DW12-20X2000	16	20	300	2000	30
DW12-20X2500	16	20	340	2500	30
DW12-25X2500	20	25	390	2500	30+7.5
DW12-25X3000	20	25	420	3000	37+7.5
DW12-30X2500	25	30	420	2500	37+7.5
DW12-30X3000	25	30	460	3000	45
DW12-35X2500	30	35	460	2500	45
DW12-35X3000	30	35	510	3000	55
DW12-35X3500	30	35	550	3500	55
DW12-40X2500	35	40	510	2500	55
DW12-40X3000	35	40	550	3000	55
DW12-40X3500	35	40	560	3500	55+7.5
DW12-50X2500	45	50	560	2500	55+7.5
DW12-50X3000	45	50	605	3000	55
DW12-50X3500	45	50	640	3500	75
DW12-60X3000	50	60	670	3000	75
DW12-60X3500	50	60	700	3500	75
DW12-70X3000	65	70	720	3000	90
DW12-70X3500	65	70	760	3500	90
DW12-80X3000	70	80	780	3000	90
DW12-80X3500	70	80	840	3500	55X2
DW12-80X4000	70	80	870	4000	55X2
DW12-90X3000	80	90	810	3000	75X2
DW12-90X3500	80	90	890	3500	75X2
DW12-90X4000	80	90	925	4000	75X2
DW12-100X3000	85	100	850	3000	45X4
DW12-100X3500	85	100	925	3500	45X4
DW12-100X4000	85	100	960	4000	45X4
DW12-120X3000	100	120	940	3000	55X4
DW12-120X3500	100	120	980	3500	55X4
DW12-120X4000	100	120	1020	4000	55X4
DW12-140X3000	115	140	1000	3000	75X4
DW12-160X3500	130	160	1220	3500	90X4
DW12-180X3000	150	180	1280	3500	55X8
DW12-200X4000	160	200	1500	4000	75X8



## Oil and Gas Transmission Pipe Rolling Machine

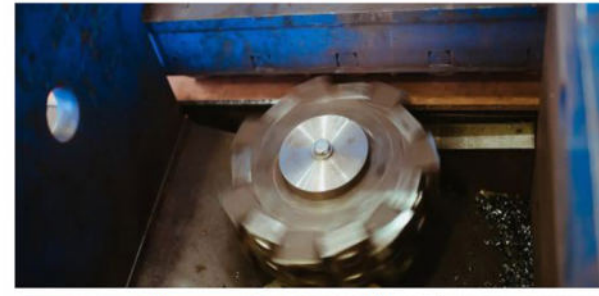

### Technical Parameters

Model	Bending thickness (mm)	Max. Plate width (mm)	Diameter of upper roller (mm)	Main motor power (kw)
DW11G-16X12000	3~16	12000	480	90
DW11G-20X12000	3~20	12000	510	110
DW11G-30X12000	4~30	12000	600	150
DW11G-40X12000	5~40	12000	800	220

### Features

The plate rolling machine for small diameter of thick plate is our patent machine developed by learning some experience from foreign country. We introduce foreign technology and combine with domestic machine features to develop our own patent plate rolling machine for rolling smaller diameter. The working performance of the kind machine is better than the similar machine in domestic, and it is of high efficiency, low energy, easy operation.

### Unique Advantages

1. The smallest diameter can be achieved is 12.5 times of plate thickness for cold rolling;
2. We use the pressing down beam to remove the deflection of top roller when rolling small diameter;
3. The straightness of rolled round cylinder can be controlled within 1/2000;
4. The distance between two lower can be adjusted, the pre-bending and bending can be both achieved;
5. The misalignment is prevented effectively by auto aligning device;
6. The rolling process is automatic due to computer control.

### It includes below technology:

1. Upper roll use the anti-deformation method to eliminate the deflection in manufacturing process;
2. We use a few groups oil cylinders to add pressure on the both sides of top roller, and the piston of oil cylinder is fixed, up-down movement to drive top roller seat over up-down, which use the space effectively, increase the material utilization and reduce the weight of whole machine;
3. When discharging the products, it is from the inside of the rack without to turnover and rest, enhanced security;
4. All of the discharging of the product all use the automatic cylinder (another patent technology of our company), suitable for line production.



## Upper Roller Universal Plate Rolling Machine



Technical Parameters

Model	Pressure on the upper roller(Tons)	Max Pre-bending thickness(mm)	Max bending thickness(mm)	Diameter of the upper roller(mm)	Max plate width(mm)	Main motor power(kw)
DW11S-8X1500	55	6	8	175	1500	3
DW11S-10X2000	60	8	10	235	2000	4
DW11S-10X2500	60	8	10	255	2500	5.5
DW11S-12X1500	60	10	12	245	1500	4
DW11S-12X2000	75	10	12	250	2000	5.5
DW11S-12X2500	75	10	12	270	2500	7.5
DW11S-13X3000	75	11	13	290	3000	7.5
DW11S-14X2500	75	11	14	270	2500	7.5
DW11S-15X2000	75	12	15	255	2000	7.5
DW11S-15X3000	100	12	15	325	3000	7.5
DW11S-16X2000	100	12	16	255	2000	7.5
DW11S-16X2500	100	12	16	300	2500	11
DW11S-20X2000	130	16	20	260	2000	11
DW11S-20X2500	130	16	20	330	2500	15
DW11S-25X2500	200	20	25	380	2500	18.5
DW11S-25X3000	200	20	25	430	3000	22
DW11S-30X2500	230	25	30	410	2500	22
DW11S-30X3000	270	25	30	450	3000	30
DW11S-35X2500	270	30	35	460	2500	30
DW11S-35X3000	300	30	35	500	3000	37
DW11S-40X2500	380	35	40	500	2500	37
DW11S-40X3000	380	35	40	540	3000	45
DW11S-50X3000	610	40	50	580	3000	55
DW11S-50X3500	610	40	50	620	3500	55
DW11S-60X3000	690	50	60	650	3000	55
DW11S-60X3500	690	50	60	680	3500	75
DW11S-60X4000	690	50	60	780	4000	75
DW11S-70X3000	850	60	70	710	3000	75
DW11S-70X3500	850	60	70	740	3500	75
DW11S-80X3000	930	70	80	760	3000	75
DW11S-80X3500	930	70	80	820	3500	75
DW11S-80X4000	930	70	80	860	4000	90
DW11S-100X3000	1150	90	100	820	3000	90
DW11S-100X3500	1150	90	100	860	3500	90
DW11S-100X4000	1350	90	100	900	4000	90
DW11S-120X3000	1350	100	120	860	3000	110
DW11S-120X4000	1600	100	120	990	4000	110
DW11S-125X3000	1600	105	125	880	3000	110
DW11S-160X4000	1800	130	160	1260	4000	2X90
DW11S-200X4000	2000	170	200	1480	4000	2X132

## Hydraulic Symmetric 3-Roller Plate Rolling Machine



Technical Parameters

Model	Max. Bending Thickness (mm)	Max. Plate Width (mm)	Yielding limit of sheet metal (Mpa)	Rolling speed (m/min)	Min. Bending Diameter (mm)	Diameter of upper roller	Diameter of lower roller	Main motor power (kw)
DW11NC-20X3000	25	3000	245	4	1200	430	370	30
DW11NC-25X2500	25	2500	245	4	1200	370	300	22
DW11NC-30X2000	30	2000	245	4	1200	360	290	22
DW11NC-30X3000	30	3000	245	4	1200	450	390	30
DW11NC-40X3000	40	3000	245	3.5	1600	540	440	45
DW11NC-50X3000	50	3000	245	3.5	2000	580	480	55
DW11NC-60X3000	60	3000	245	3.5	2400	660	560	75
DW11NC-70X3000	70	3000	245	3.5	2800	710	620	90
DW11NC-80X3000	80	3000	245	3.5	3200	770	680	90
DW11NC-90X3000	90	3000	245	3.5	3600	820	730	110
DW11NC-100X3000	100	3000	245	3.5	4000	860	770	110
DW11NC-110X3000	110	3000	245	3.5	4400	900	810	132
DW11NC-120X3000	120	3000	245	3.5	4800	950	860	132



### 3-Roller Plate Rolling Machine for Shipbuilding



#### Technical Parameters

Model	Max bending thickness (mm)	Plate width(mm)	Yielding Limit Mpa	Diameter of upper roller(mm)	Main motor power (kw)
DW11V-5X7000	5	7000	245	440	11
DW11V-6X9500	6	9500	245	500	15
DW11V-8X6000	8	6000	245	420	15
DW11V-8X7000	8	7000	245	450	15
DW11V-8X8000	8	8000	245	470	15
DW11V-8X9500	8	9500	245	510	15
DW11V-10X6000	10	6000	245	440	15
DW11V-10X9000	10	9000	245	470	15
DW11V-12X6000	12	6000	245	460	15
DW11V-12X9000	12	9000	245	530	22
DW11V-16X6000	16	6000	245	500	22
DW11V-20X6000	20	6000	235	550	30

#### Technical Parameters

Model type	Max. thickness (mm)	Yield limit (Mpa)	Max. width (mm)	Max. thickness (mm)	Diameter of upper roller(mm)	Rolling speed (m/min)	Main motor power(Kw)	Outline size (mm)	Weight (kg)
DW11H-4X2500	2	245	2500	2	160	5.2	5.5	3.17X1.17X1.32	4600
DW11H-6X2000	4	245	2000	6	160	5.2	5.5	3.21X1.17X1.31	4000
DW11H-6X2500	4	245	2500	6	190	5	5.5	3.71X1.17X1.31	5800
DW11H-8X2000	5	245	2000	8	190	5	5.5	3.21X1.17X1.31	4200
DW11H-8X2500	5	245	2500	8	230	5	5.5	4.65X1.32X1.45	6200
DW11H-8X3200	6	245	3200	8	270	5	7.5	5.12X1.62X1.62	7300
DW11H-12X2000	8	245	2000	12	230	5	5.5	4.15X1.32X1.49	6000
DW11H-12X2500	8	245	2500	12	270	4.5	7.5	4.42X1.62X1.64	7000
DW11H-12X3200	8	245	3200	12	300	5	18.5	5.58X1.36X1.49	9200
DW11H-16X2000	12	245	2000	16	270	5	7.5	3.29X1.62X1.62	6800
DW11H-16X2500	12	245	2500	16	300	5	18.5	4.88X1.36X1.49	8400
DW11H-16X3200	12	245	3200	16	330	5	18.5	5.33X1.96X1.75	13500
DW11H-16X4000	12	245	4000	16	380	5	18.5	6.13X1.96X1.75	18000
DW11H-20X2000	14	245	2000	20	300	5	18.5	4.38X1.36X1.49	8000
DW11H-20X2500	14	245	2500	20	330	4	18.5	4.63X1.96X1.75	12000
DW11H-20X3200	14	245	3200	20	330	4	18.5	5.33X1.96X1.75	15000
DW11H-25X2000	20	245	2000	25	330	4	18.5	4.63X1.96X1.75	13000
DW11H-25X3200	20	245	3200	25	420	4	22	5.3X2.42X2.51	22000
DW11H-32X2000	25	245	2000	32	360	4	22	4.5X2.42X2.51	16000
DW11H-35X2500	25	245	2500	35	460	4	30	5.7X2.85X2.97	22000

### 3-Roller Plate Rolling Machine for Vehicle



#### Technical Parameters

Model	Max bending thickness(mm)	Max plate width(mm)	Yielding Limit(Mpa)	Main motor power(kw)
DW11C-20X8000	20	8000	245	45
DW11C-25X12000	25	12000	245	55
DW11C-30X12000	30	12000	245	75
DW11C-30X16000	30	16000	245	110

#### The Other 3-Roller Plate Rolling Machine



#### Technical Parameters

Specification	Max. thickness of coiled plate (mm)	Max. width of coiled plate (mm)	Max. thickness prefix (mm)	Yield limit (Mpa)	Diameter of upper roller (mm)	Main motor power(KW)
DW11XNC-35X3000	35	3000	30	245	520	45
DW11XNC-40X2500	40	2500	35	245	510	45
DW11XNC-40X3000	40	3000	35	245	550	55
DW11XNC-40X4000	40	4000	32	245	630	55
DW11XNC-55X3000	55	3000	45	245	630	75
DW11XNC-65X4000	65	4000	60	245	840	90
DW11XNC-75X3000	75	3000	65	245	750	90
DW11XNC-90X3000	90	3000	75	245	820	110
DW11XNC-100X3000	100	3000	90	245	880	110
DW11XNC-120X3000	120	3000	100	245	920	132
DW11XNC-160X4000	160	4000	130	245	1280	220



## Iron Worker

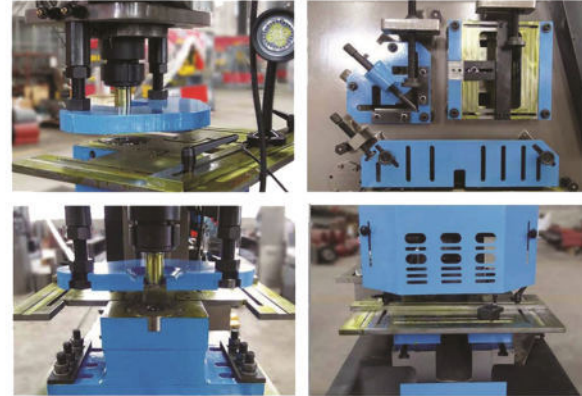

### FEATURES

Hydraulic transmission, is the latest product of the multi-function joint punching and shearing machine, shearing, punching, die cut flat steel, square steel, round steel, angle steel, channel steel, I-beam carried, and equipped with shear blockfeeding devices.



Sunny Pump

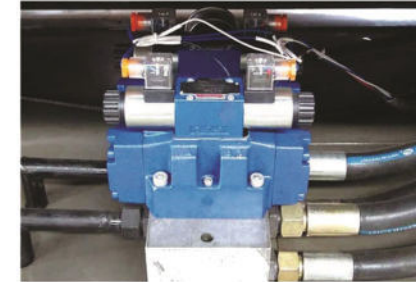

Rexroth Valve



Schneider Electrics



Siemens Motor

### TECHNICAL PARAMETERS

MODEL	DMIW-16	DMIW-20	DMIW-25	DMIW-30	DMIW-40
Punching Pressure (T)	60T	90T	120T	160T	200T
Max. cutting thickness of sheet plates (mm)	16	20	25	30	40
Material strength (N/mm)	≤450	≤450	≤450	≤450	≤450
Angle of shear (°)	7°	8°	8°	8°	8°
Flat bar shearing (T×W)	16×250 8×400	20×330 10×480	25×330 16×600	30×335 20×600	40×335 30×600
Max. length of cylinder stroke (mm)	80	80	80	80	100
Trips frequency (times/min)	11-20	12-20	8-18	6-16	6-16
Depth of throat (mm)	300	355	400	600	530
Punch depth (mm)	16	20	25	28	35
Max. punching diameter (mm)	25	30	35	38	40
Motor Power (KW)	5.5	7.5	11	15	18.5
Overall dimensions (L×W×H) (approx.)	1740×810×1830	1950×900×1950	2355×960×2090	2800×1050×2450	2900×1100×2500

(I-BEAM, CHANNEL STEEL NEEDS TO BE ORDERED SEPERATELY)

PROFILE	SECTION	DMIW-16	DMIW-20	DMIW-25	DMIW-30	DMIW-40
Round Bar		45	50	60	65	70
Square Bar		40×40	50×50	50×50	55×55	60×60
Equal Angle	90° Shearing	120×120×12	140×140×12	160×160×14	180×180×16	200×200×18
	45° Shearing	50×50×5	70×70×10	60×60×6	80×80×8	80×80×10
T-Bar	90° Shearing	125×125×12	140×140×12	160×160×14	180×180×16	200×200×18
	45° Shearing	60×60×8	70×70×10	80×80×10	80×80×10	100×100×10
I-beam		120×74×5	160×88×6	200×102×9	280×124×10.5	300×130×13
Channel		120×53×5.5	160×63×6.5	200×75×9	280×86×11.5	300×89×11.5



## Hydraulic Press Machines

Manual H Frame Press



H Frame Hydraulic Press



H Frame Press with Moving Cylinder



HYDRAULIC PRESS

HYDRAULIC PRESS

### Features

- HP series hydraulic press are used for assembling, dismantling, alignment, calendaring, tension, bending and punching.
- The machine supplied oil by Italy CNK and CBZ pump. It could save 60% energy compared with the traditional model. The efficiency increased to 2-3 times. It takes the advantages of small volume, high pressure, simple structure and light weight.

### Application

- The machine is suitable for operating in the open air or the other special situation.



	MODEL	CAPACITY KN	PRESSURE MPA	TRAVEL MM	TABLE SIZE MM	DIMENSION MM	WEIGHT KG
Manual H frame Press	DHP-10S	100	50	160+370	197x455	670x520x1210	55
	DHP-20S	200	50	200+450	200x300	500x350x1300	260
	DHP-30S	300	50	200+450	300x400	550x400x1500	320
	DHP-50S	500	60	250+450	360x680	1000x600x1750	460
	DHP-63S	630	30	220+405	400x500	1500x650x1950	1020
	DHP-100S	1000	45	260+450	400x600	1600x720x2000	720/820
H Frame Hydraulic Press	DHP-150S	1500	40	260+450	800x400	1730x720x2150	1100
	DHP-20	200	25	200+270	200*300	1160*550*1600	400
	DHP-30	300	25	200+270	300x400	1160x550x1600	420
	DHP-50	500	25	220+405	360x480	1500x650x1950	980
	DHP-63	630	30	220+405	400x500	1500x650x1950	1020
	DHP-100	1000	31.5	250+405	700x460	1730x730x2250	1220
H Frame Press with Moving Cylinder	DHP-150	1500	30	250+405	440x980	1730x730x2250 630x730x960	1350
	DHP-200	2000	31.5	300+405	980x500	1940x950x2350 900x800x1060	2200
	DHP-20M	200	25	220+405	400x500	1300x650x1750	980
	DHP-30M	300	25	220+405	400x500	1500x650x1950	980
	DHP-50M	500	25	220+405	400x500	1500x650x1950	980
	DHP-63M	630	25	220+405	400x500	1500x650x1950	1020
	DHP-100M	1000	30	250+405	440x980	1730x730x2250 730x630x960	1220
	DHP-150M	1500	30	250+405	440x980	1730x730x2250 730x630x960	1350
DHP-200M	2000	31.5	300+405	500x1000	1940x950x2350 900x800x106	2200	
DHP-300M	3000	31.5	300+405	700x1200	2100x950x2700 1100x1200x1350	4200	



## Pneumatic Press Machine

### JH21 Series Punch Press



#### Features

- Steel plate welded body, stiffness, more stable.
- Dry pneumatic friction clutch - brake, friction machine for semi - metallic materials.
- The imported safe double valve control, quick, safe and reliable
- Mold height realize electric adjustment, digital display control height.
- Slider use rectangle hexahedron extended guide, bronze lining board, high guidance accuracy.
- International famous brand special press control system,
- Automatic feeding device and all kinds of automation equipment

#### Application

- Suitable for blanking, punching, forming, bending, stretching and other cold stamping process to achieve.
- Widely used in electrical appliances, vehicles, tractors, mining machinery, hardware tools, machinery manufacturing and other industrial areas.

Specification	Units	JH21-25	JH21-45	JH21-63	JH21-80
Nominal pressure	KN	250	450	630	800
Nominal force stroke	mm	3	4	4	5
Slider stroke	mm	80	100	120	140
Number of slider stroke	s. p .m	100	80	70	60
Max. die set height	mm	250	270	300	320
Die set height adjustment	mm	50	60	80	80
Distance from slider center to frame	mm	210	230	300	300
Worktable dimension(L x W)	mm	400x700	440x810	580x900	580x1000
Workbench plate hole size	mm	Φ150	Φ160	Φ180	Φ180
Thickness of the worktable panel	mm	80	110	110	120
Slider ground size (L x W)	mm	250x360	340x410	400x480	420x560
Size of the handle hole (diameter *depth)	mm	Φ40 x60	Φ40 x6	Φ50 x80	Φ50 x80

## Four Column Deep Drawing Hydraulic Press



#### Features

- The host of the series of products using three beam four column structure, hydraulic system 100 tons below the use of plate type integrated oil circuit, 100 tons or more of the cartridge valve oil circuit, electrical system using relay or PLC control circuit, centralized operation via an external button, can realize the adjustment and semi automatic operation mode. Whole machine has the advantages of simple structure, compact structure, reasonable economy, reliable operation, long service life, small hydraulic impact force, and reduced connection pipeline and leakage.
- Work pressure of the series products, pressing speed, travel range can be adjusted according to the requirements within the specified range, can achieve constant pressure and constant stroke of two kinds of Technology. When the constant pressure is formed, the pressure holding time delay and the automatic return stroke are pressed. A top out device is arranged in the middle of the working table, in addition to the top products, can be used as hydraulic cushion for the forming process of drawing parts.

SPECIFICATIONS	UNITS	DM60T	DM100T	DM160T	DM200T	DM500T	DM630T
Nominal force	KN	600	1000	1600	2000	2500x2	3150x2
Ejector force	KN	200	400	400	630	1000	1000
Max. working force of liquid	MPA	25	25	25	25	25	25
Slide stroke	mm	450	400	800	800	900	800
Ejection stroke	mm	200	200	300	300	300	300
Table effective size	mmxmm	580x500	800x800	1600x1200	1000x1000	2500x1400	1260x1200
Empty stroke descent speed	mm/s	100	120	120	130	120	130
Slow down speed	mm/s	25	35	30	30	25	30
Pressing speed	mm/s	9	10	15	12	6-10	9
Return speed	mm/s	80	80	90	80	70	80
Motor power	KW	5.5	7.5	11	15	37	37



## Hydraulic Press



## STANDARD EQUIPMENT

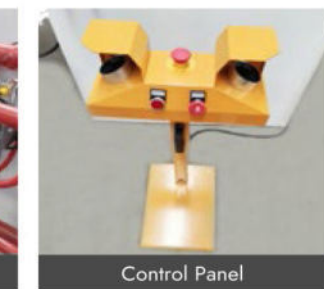
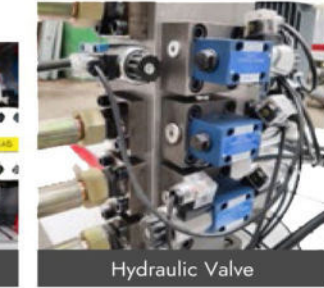
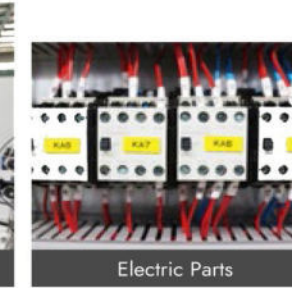

## SPECIFICATION FOUR-COLUMN HYDRAULIC PRESS

Model		D4HP-63T	D4HP-100T	D4HP-160T	D4HP-200T	D4HP-260T	D4HP-315T	D4HP-400T	D4HP-500T	D4HP-630T	D4HP-800T	D4HP-1000T	D4HP-1260T	D4HP-1600T	D4HP-2000T	D4HP-2500T	D4HP-3000T	
Nominal Force	KN	630	1000	1600	2000	2500	3150	4000	5000	6300	8000	10000	12500	16000	20000	25000	30000	
Return Force	KN	160	250	250	400	630	630	630	1000	1600	2000	2000	2000	2500	3150	4000	5000	
Daylight	mm	800	800	1000	1120	1120	1250	1250	1500	1500	1500	1600	1500	1600	1800	2000	2000	
Slide Stroke	mm	500	500	650	710	710	800	800	900	900	900	1000	1000	1000	1200	1200	1200	
Rejection Stroke	mm	200	200	200	250	250	300	360	360	360	360	450	400	450	450	500	500	
Speed Of Slide	Descent	mm/s	40	70	40	80	>150	120	100	>100	>100	>100	>150	>150	>150	>150	>150	>150
	Pressing	mm/s	7	15	8	5-12	6-15	5-12	4-10	4-10	5-12	5-12	4-10	4-10	4-10	4-10	5-12	
Table Size	Return	mm/s	580	100	65	70	>150	65	70	50	100	90	100	85	>100	160/60	≥100	120
	L-R	mm	550	630	800	900	1000	1200	1200	1400	2000	2000	2000	2500	2500	3000	3500	4000
Table High Above Floor	F-B	mm	630	630	800	900	1000	1200	1200	1400	1600	1600	1800	2000	2000	2500	2500	2600
	L-R	mm	700	700	550	550	650	700	600	500	500	300	300	200	200	200	200	
Overall Dimensions	L-R	mm	2370	2370	1150	3200	5400	3180	3785	4070	4390	4800	7010	5890	6500	6870	7630	8530
	F-B	mm	900	900	800	900	1500	1200	1200	1648	2150	2854	3000	3450	3900	2500/4500	5000	4000
Motor Power	KW	2770	2770	2600	4085	4740	4570	4667	5348	5300	5400	5740	6980	7500	7500	7840	8500	

## OPTIONAL EQUIPMENT





## Hydraulic Press



### Standard Equipment



### Technical Parameters

Model		DDHP-200	DDHP-250	DDHP-316	DDHP-400	DDHP-400A	DDHP-500	DDHP-500A	DDHP-500B	DDHP-630	DDHP-630A	DDHP-800	DDHP-800A	DDHP-1000	DDHP-1000A	DDHP-1250	DDHP-1600	DDHP-2000	DDHP-2500	DDHP-3000	
Nominal Force	KN	2000	2500	3150	4000	4000	5000	5000	2500*2	6300	3150*2	8000	8000	10000	10000	12500	16000	20000	25000	30000	
Return Force	KN	240	400	600	500	500	900	900	400	850	600*2	900	900	1250	1250	1250	2000	2000	2250	2250	
Working Pressure	Mpa	25	25	25	25	25	25	25	25	25	25	25	25	25	25	25	25	25	25	25	
Cushion Pressure	KN	400	400	630	1000	1000	1600	2000	1000	2500	1250*2	1000	1000	1600	1600	1600	2400	2400	3000	3000	
Cushion Return Force	KN	250	320	360	360	360	780	780	320*2	720	360*2	3000	3000	5000	5000	5000	5000	2500	800	1000	
Daylight Of Slide	mm	1120	1120	1250	1250	1250	1500	1500	1500	1500	1500	1800	1800	1800	2200	1800	2000	2100	2000	2500	
Stroke	Upper Slide	mm	710	710	800	800	800	900	900	900	900	1200	1200	1000	1500	1000	1200	1300	1100	1600	
	Cushion	mm	250	250	300	300	300	350	350	350	350	400	400	365	500	400	400	350	400	400	
Table Size	L-R	mm	1000	1100	1260	1250	1750	1400	2200	2200	1600	2500	3200	3200	3200	4000	4000	4000	4500	4500	4500
	F-B	mm	940	1000	1160	1250	1400	1600	1600	1600	1800	2200	2200	2300	2300	2500	2500	2500	2500	2500	2500
Cushion Size	L-R	mm	660	700	820	820	1270	970	1720	1720	1120	2020	2550	2550	2550	3500	3370	3820	3750	3820	2600
	F-B	mm	600	600	700	820	820	900	1120	1120	1270	1700	1700	1800	1800	1870	1870	1800	1700	1600	
Speed Of Slide	Descent	mm/s	150	130	100	130	130	120	150	150	130	140	300	300	300	300	350	350	350	350	350
	Pressing	mm/s	5-12	7-15	5-12	4-10	4-10	7-15	7-15	7-15	5-12	5-12	8-22	8-22	12-30	12-30	12-30	12-30	12-30	12-30	12-30
Table High Above Floor	Return	mm/s	95	90	60	70	70	80	90	90	85	85	200	200	250	250	300	300	300	300	300
	L-R	mm	700	700	600	600	600	550	550	550	500	500	500	720	900	400	400	400	350	350	350
Overall Dimensions	F-B	mm	3100	3250	3100	3150	3700	5800	6600	6600	4150	5100	5400	5400	5400	6200	6200	6200	6700	6700	6700
	Motor Power	KW	15	22	22	22	22	2*22	2*22	2*22	2*22	2*22	96	105	160	160	160	200	380	410	500

### Optional Equipment

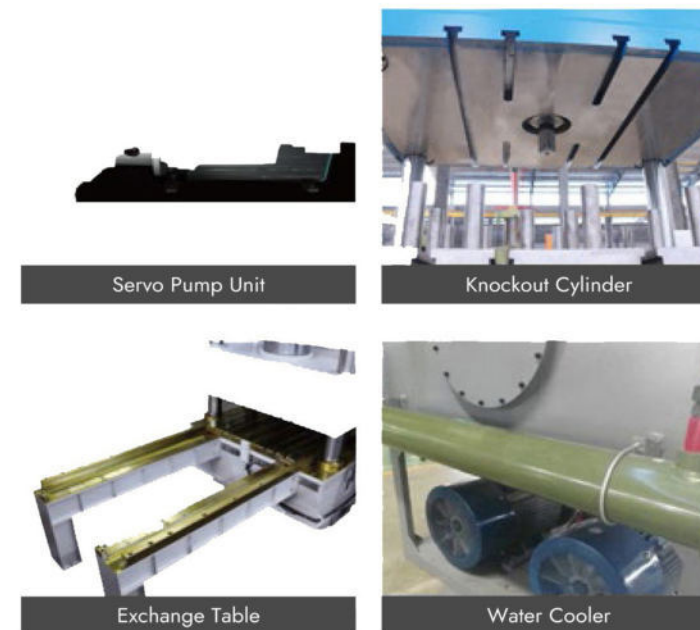



## Hydraulic Press

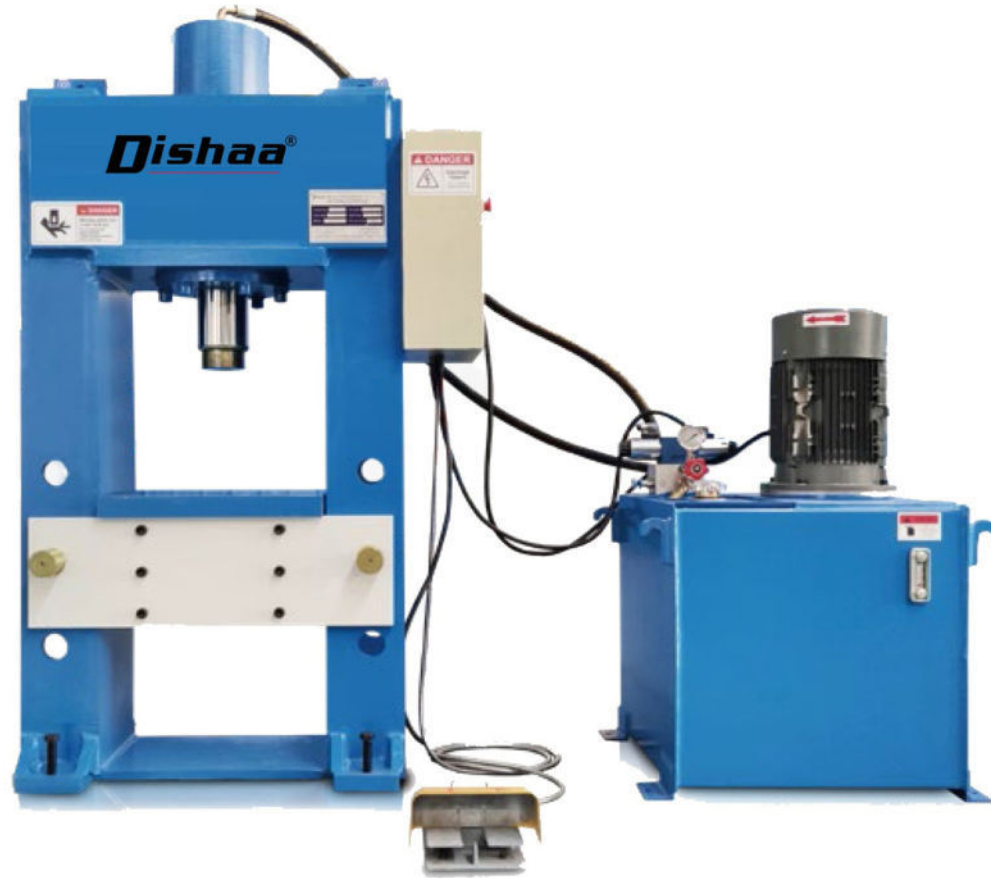

- Adopt Gantry frame type structure, welded by high quality steel plate.
- The forged steel is quenched and treated, with high hardness and long service life.
- Polished and chromed with high rigidity treatment.
- Adjustable opening height (daylight).
- Check the hydraulic oil volume and temperature.
- The main seal of the cylinder adopts high quality seal ring to ensure reliable sealing.
- There are T-slots on the working table and slider, which are convenient for mold installation.

### Standard Equipment

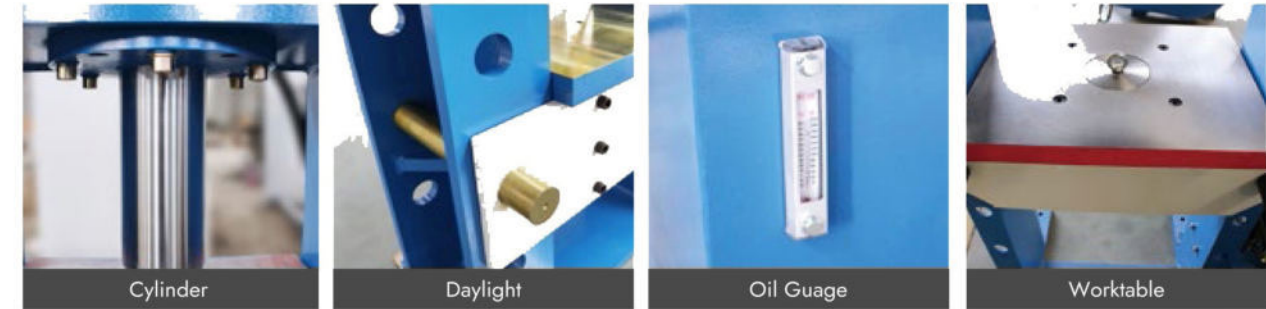

### Optional Equipment



### Technical Parameters

Model		DL-20T	DL-20TK	DL-40T	DL-40TK	DL-60T	DL-60TK	DL-100T	DL-100TK
Nominal Force	KN	200	200	400	400	600	600	1000	1000
Stroke	mm	200	200	200	200	200	200	350	350
System Pressure	Mpa	25	25	30	30	30	30	25	25
Working Table Size (Left And Right)	mm	360	400	400	400	400	400	440	440
Working Table Size (Front And Back)	mm/s	400	460	460	460	490	490	650	650
Down Speed	mm/s	15	40	6	45	6	45	6	16
Return Speed	mm/s	23	50	8	60	8	60	8	20
Motor Power	KW	2.2	4	2.2	7.5	2.2	7.5	7.5	7.5



## Power Press Machine



### Features

- Steel plate welding machine, good rigidity, more stable accuracy.
- Crankshaft longitudinal, compact structure, beautiful appearance.
- Electric adjustment of the height of the mould, digital display control height.
- Rectangular block with a lengthened guide, bronze lining board, high guidance accuracy.
- Combined pneumatic friction clutch brake, joint stable, action sensitivity.
- Collapse type safety device, to ensure the safety of the whole machine.
- Slider is high, there is a lifting type balance cylinder, to achieve the balance of the slider bar.
- The slider can be moved with a small movement, emergency stop motion, more secure operation.
- The circuit uses double valve control, the action is nimble, accord with the safety standard of press.

### Application

- Suitable for blanking, punching, forming, bending, stretching and other cold stamping process to achieve.
- Widely used in electrical appliances, vehicles, tractors, mining machinery, hardware tools, machinery manufacturing and other industrial areas.

Specification	Units	JB23-16	JB23-63	JB23-80	JB23-100	
Nominal pressure	KN	160	630	800	1000	
Nominal force stroke	mm	2	4	5	5	
Slider stroke	mm	50	80	100	100	
Number of slider stroke	/min	140	50	50	40	
Maximum die set height	mm	170	250	300	300	
Die set height adjustment	mm	30	50	60	80	
Distance from slider center to frame	mm	160	250	260	310	
Worktable dimension	mm	320x460	420x650	470x750	570x860	
Thickness of the worktable panel	mm	45	70	80	90	
Size of the handle hole (diameter x depth)	mm	cp40x60	cp50x70	cp60x80	cp60x80	
Vertical columns distance	mm	240	320	300	420	
Main motor	Model	Y90L-4	Y132S-4	Y132S-4	Y132M-4	
	Power	KW	1.5	5.5	5.5	7
Maximum tilting angle of body	°	25	25	20	20	
Overall dimension (L x W x H)	mm	1130X830X1890	1740X1100X256	1765X1265X2560	1940X1490X2850	
Weight	Kg	1090	3800	5015	6120	

## Arbor Press



### Performance Characteristics

- The Arbor presses have the advantages of small volume, simple structure.
- High quality cast-iron body, sturdy design.
- For press-fitting and pulling bearings, 4-position plate.
- Chrome-plate steel pinion and ram.

### Applications

The machine is suitable for operating in the open air or the other special situation.

Specification	Units	½ TON	1 TON	2 TON	3 TON	5 TON
Capacity	Ton	0.5	1	2	3	5
Max height & dia	MPA	90x80	110x100	180x123	285x163	400x226
Largest Arbor	mm	26	29	40	44	70
Ram square	mm	19x19	25x25	32x32	38x38	50x50
Base size	mm	240x170	268x190	432x260	455x300	645x176
Press Ht	mm	280	355	445	615	815
Dimension	cm	26x12x29	29x14x35	46x20x45	46x24x64	76x37x95
N.W/G.W	Kg	11/12	15/16	36/38	63/65	155/166



## Lathe Machine

### DSL250 / DSL280 DSL320B / DSL360 Lathe Machine



- Feature**
- Precision spindle bearing
  - All geared spindle box
  - Longitudinal and cross automatic feed
  - Quenched and precision grinding guide way

SPECIFICATIONS		Units	DSL250	DSL280	DSL320B	DSL360
Swing over bed	mm		250	280	320	360
Swing over cross slide	mm		150	165	200	240
Distance between centers	mm		500(Opt.700)	500(Opt.750)	600(Opt.750)	750
Spindle bore	mm		26	38	38	38
Spindle bore taper	-		MT4	MT5	MT5	MT5
Spindle speed steps	-		12	8	12	12
Spindle speed range	rpm		80-1600	90-1800	80-1600	80-2000
Cross slide travel	mm		130	140	160	180
Top tool post travel	mm		75	75	100	100
Longitudinal feeds range	mm/r		0.03-0.275	0.05-0.35	0.1-1.4	0.1-1.4
Cross feeds range	mm/r		0.015-0.137	0.025-0.18	0.045-0.6	0.045-0.60
Kinds of metric threads	kinds		15	18	22	22
Range of metric threads	mm		0.25-2.5	0.2-3.5	0.2-7	0.2-7
Kinds of inch threads	kinds		9	34	45	45
Range of inch threads	T.P.I.		12-96	4 1/2 -48	2 1/2 -48	2 1/2 -48
Kinds of module threads	kinds		-	16	21	21
Range of module threads	MP		-	0.20-1.75	0.2-3.5	0.20-3.5
Kinds of pitch threads	kinds		-	24	31	31
Range of pitch threads	DP		-	16-120	8-120	8-120
Tailstock quill taper	-		MT3	MT3	MT3	MT3
Tailstock quill travel	mm		60	60	80	80
Main motor power	kw		0.75	0.75	0.75	1.1
Machine weight	Weight for 500	kg	180	300	-	-
	Weight for 600	kg	-	-	450	-
	Weight for 700	kg	200	-	-	-
	Weight for 750	kg	-	320	480	550
Overall dimension	Dimension for 500	mm	1130*550*1170	1200*650*1200	-	-
	Dimension for 600	mm	-	-	1370*685*1360	-
	Dimension for 700	mm	200	-	-	-
	Dimension for 750	mm	-	1450*650*1200	1520*685*1360	1370*705*1430

### D6132D / D6136 / D6140 Lathe Machine



SPECIFICATIONS		Units	D6132D	D6232D	D6136D	D6236D	D6140D	D6240D
Swing over bed	mm		320		360		400	
Swing over cross slide	mm		180		200		240	
Swing over gap	mm		-	500	-	540	-	580
Distance between centers	mm		750/1000		750/1000		750/1000	
Spindle bore	mm		52		52		52	
Spindle bore taper	-		MT6		MT6		MT6	
Spindle speed steps	steps		12		12		12	
Spindle speed range	rpm		30-1600		30-1600		30-1600	
Cross slide travel	mm		240		240		240	
Top tool post travel	mm		140		140		140	
Tool size	mm		20 * 20		20 * 20		20 * 20	
Longitudinal feeds range	mm/r		0.039-1.05		0.039-1.05		0.039-1.05	
Cross feeds range	mm/r		0.019-0.52		0.019-0.52		0.019-0.52	
Kinds of metric threads	kinds		25		25		25	
Range of metric threads	mm		0.5-20		0.5-20		0.5-20	
Kinds of inch threads	kinds		35		35		35	
Range of inch threads	T.P.I.		1 1/4 -80		1 1/4 -80		1 1/4 -80	
Tailstock quill diameter	mm		60		60		60	
Tailstock quill taper	-		MT4		MT4		MT4	
Tailstock quill travel	mm		100		100		100	
Main motor power	kw		3		3		4	
Coolant motor power	kw		0.09		0.09		0.09	
Machine weight	Weight for 750	kg	1400		1500		1700	
	Weight for 1000	kg	1500		1600		1800	
Overall dimension	Dimension for 750	mm	2200*1140*1600		2200*1140*1600		2200*1140*1600	
	Dimension for 1000	mm	2400*1140*1600		2400*1140*1600		2400*1140*1600	



## Lathe Machine

DZ1224G / DZ1237G  
DZ1324G / DZ1337G

Lathe Machine



### Feature

- Precision spindle bearing
- All geared spindle box
- Longitudinal and cross automatic feed
- Quenched and precision grinding guide way

SPECIFICATIONS	Units	DZ1224G	DZ1237G	DZ1324G	DZ1337G
Swing over bed	mm	305	305	330	330
Swing over cross slide	mm	173	173	215	215
Swing over gap	mm	440	440	485	485
Distance between centers	mm	530	940	530	940
Spindle bore	mm	38	38	38	38
Spindle bore taper	-	MT5	MT5	MT5	MT5
Spindle speed steps	-	9	9	9	9
Spindle speed range	rpm	64-1500	64-1500	64-1500	64-1500
Cross slide travel	mm	150	150	150	150
Top tool post travel	mm	85	85	85	85
Feeds range	mm/r	0.051-0.303	0.051-0.303	0.051-0.303	0.051-0.303
Kinds of metric threads	kinds	11	11	11	11
Range of metric threads	mm	0.5-3.5	0.5-3.5	0.5-3.5	0.5-3.5
Kinds of inch threads	kinds	14	14	14	14
Range of inch threads	T.P.I.	7 1/2-48	7 1/2-48	7 1/2-48	7 1/2-48
Tailstock quill diameter	mm	32	32	32	32
Tailstock quill taper	-	MT3	MT3	MT3	MT3
Tailstock quill travel	mm	95	95	95	95
Main motor power	kw	1.1	1.1	1.1	1.1
Coolant pump motor	kw	0.04	0.04	0.04	0.04
Machine weight	kg	420	440	440	460
Overall dimension	mm	1780x750x1460	1420x750x1460	1780x750x1480	1420x750x1480

DZ1237G/1 DZ1337G/1  
DZ1340G/1 DZ1440G/1

Lathe Machine



### Feature

- Precision spindle bearing
- All geared spindle box
- Longitudinal and cross automatic feed
- Quenched and precision grinding guide way
- Cam-lock spindle nose
- Wide range of thread processing

SPECIFICATIONS	Units	DZ1237G/1	DZ1337G/1	DZ1340G/1	DZ1440G/1
Swing over bed	mm	305	330	330	350
Swing over cross slide	mm	173	195	195	220
Swing over gap	mm	440	476	476	500
Distance between centers	mm	940	940	1000	1000
Spindle bore	mm	38	38	38(Optional:51)	38(Optional:51)
Spindle bore taper	-	MT5	MT5	MT5	MT5
Spindle speed steps	-	9	9	8	8
Spindle speed range	rpm	64-1500	64-1500	70-2000(Optional:84-1850)	70-2000(Optional:84-1850)
Cross slide travel	mm	150	150	170	170
Top tool post travel	mm	85	85	74	74
Longitudinal feeds range	mm/r	0.052-1.392	0.052-1.392	0.052-1.392	0.052-1.392
Cross feeds range	mm/r	0.014-0.38	0.014-0.38	0.014-0.38	0.014-0.38
Kinds of metric threads	kinds	26	26	26	26
Range of metric threads	mm	0.4-7	0.4-7	0.4-7	0.4-7
Kinds of inch threads	kinds	34	34	34	34
Range of inch threads	T.P.I.	4-56	4-56	4-56	4-56
Kinds of threads module	kinds	16	16	16	16
Range of threads module	MP	0.35-5	0.35-5	0.35-5	0.35-5
Kinds of threads hreads diametral	kinds	36	36	36	36
Range of threads hreads diametral	DP	6-104	6-104	6-104	6-104
Tailstock quill diameter	mm	32	32	32	32
Tailstock quill taper	-	MT3	MT3	MT3	MT3
Tailstock quill travel	mm	95	95	95	95
Main motor power	kw	1.1	1.1	1.5	1.5
Coolant pump motor	kw	0.04	0.04	0.04	0.04
Machine weight	kg	515	525	635	645
Overall dimension	mm	1780x760x1460	1780x760x1480	1920x760x1480	1920x760x1500



## Lathe Machine

D6132 / D6136 / D6140  
D6150 / D6160 / D6170

## Lathe Machine



### Main features

- Rail width is 360mm
- Thread processing need to change gears
- Tool size is 20x20mm
- Gears is steel of precision grinding and hardened

### Standard configuration

- Hook wrench
- Inner hexagon spanner
- Single-ended wrench
- Socket wrench
- 3-jaw chuck
- Dead center
- Center sleeve
- Triangular belt
- Adjustment pad iron
- Foundation bolts
- Change gears

### Optional configuration

- Steady Rest, Follow rest
- DRO
- Chuck cover ,Tool post cover ,Lead screw cover
- Foot brake
- Fast moving
- Live center
- 4 jaw chuck
- Drill chuck and holder
- Face plate
- Quick change tool post
- Taper turning attachment

SPECIFICATIONS	Units	D6132	D6232	D6136	D6236	D6140	D6240	D6150	D6250	D6160	D6260	D6170	D6270
Swing over bed	mm	320		360		400		500		600		700	
Swing over cross slide	mm	150		190		230		330		400		500	
Swing over gap	mm	-	480	-	520	-	560	-	660	-	760	-	860
Distance between centers	mm	750/1000/1500/2000/3000											
Spindle bore	mm	52(pot.80)		52(pot.80)		52(pot.80)		52(pot.80)		52(Optional:80)		52(pot.80)	
Spindle bore taper	-	MT6 (pot. Metric 1:20)		MT6 (pot. Metric 1:20)		MT6 (pot. Metric 1:20)		MT6 (pot. Metric 1:20)		MT6 (pot. Metric 1:20)		MT6 (pot. Metric 1:20)	
Spindle speed steps	steps	9		9		9		9		9		9	
Spindle speed range	rpm	40-1400		40-1400		40-1400		40-1400		40-1400		40-1400	
Cross slide travel	mm	160		180		200		250		300		350	
Top tool post travel	mm	95		95		95		95		95		95	
Tool size	mm	20*20		20*20		20*20		20*20		20*20		20*20	
Longitudinal feeds range	mm/r	0.0832-4.6569		0.0832-4.6569		0.0832-4.6569		0.0832-4.6569		0.0832-4.6569		0.0832-4.6569	
Cross feeds range	mm/r	0.048-2.688		0.048-2.688		0.048-2.688		0.048-2.688		0.048-2.688		0.048-2.688	
Kinds of metric threads	kinds	19		19		19		19		19		19	
Range of metric threads	mm	0.25-14		0.25-14		0.25-14		0.25-14		0.25-14		0.25-14	
Kinds of inch threads	kinds	28		28		28		28		28		28	
Range of inch threads	T.P.I.	2-40		2-40		2-40		2-40		2-40		2-40	
Kinds of threads module	kinds	17		17		17		17		17		17	
Range of threads module	MP	0.25-3.5		0.25-3.5		0.25-3.5		0.25-3.5		0.25-3.5		0.25-3.5	
Tailstock quill diameter	mm	65		65		65		65		65		65	
Tailstock quill taper	-	MT4		MT4		MT4		MT5		MT5		MT5	
Tailstock quill travel	mm	130		130		130		130		130		130	
Main motor power	kw	4		4		4		5.5		5.5		5.5	
Coolant pump motor	kw	0.09		0.09		0.09		0.09		0.09		0.09	
Machine weight	Weight for 750	kg	1100		1200		1220		1250		1300		1500
	Weight for 1000	kg	1200		1300		1320		1350		1400		1600
	Weight for 1500	kg	1400		1500		1520		1550		1600		1800
	Weight for 2000	kg	1600		1700		1720		1750		1800		2000
	Weight for 3000	kg	1800		1900		1920		1950		2000		2200
Overall dimension	Dimension for 750	mm	2200*1140*1500		2200*1140*1500		2200*1140*1550		2200*1140*1650		2200*1140*1750		2200*1140*1850
	Dimension for 1000	mm	2400*1140*1500		2400*1140*1500		2400*1140*1550		2400*1140*1650		2400*1140*1750		2400*1140*1850
	Dimension for 1500	mm	2900*1140*1500		2900*1140*1500		2900*1140*1550		2900*1140*1650		2900*1140*1750		2900*1140*1850
	Dimension for 2000	mm	3400*1140*1500		3400*1140*1500		3400*1140*1550		3400*1140*1650		3400*1140*1750		3400*1140*1850
	Dimension for 3000	mm	4400*1140*1500		4400*1140*1500		4400*1140*1550		4400*1140*1650		4400*1140*1750		4400*1140*1850



## Lathe Machine

**DL6140 / DL6150 / DL6161  
DL6106 / DL6180**

Lathe Machine

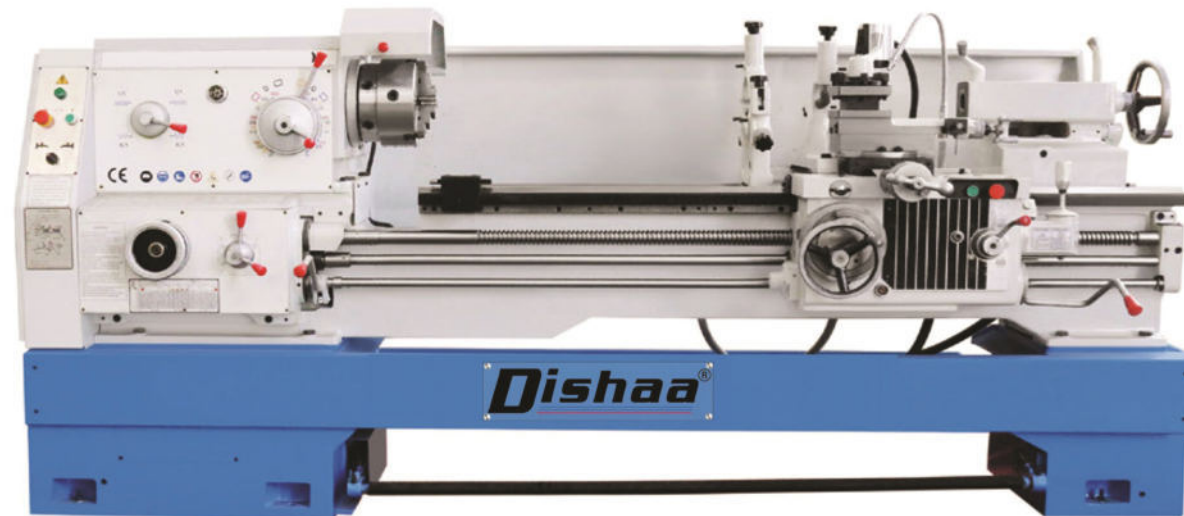

### Main features

- Guideway width 400mm, strong cutting force and stable type.
- Feed box with fast moving
- Many kinds of threads with don't need change the hanging wheel.
- 25x25mm High strength tool carrier is 25x25mm
- Gear using chrome material, more wear-resistant.
- Heavy cutting

### Standard configuration

- 3-jaw chuck
- Dead center
- Center sleeve
- Triangular belt
- Foundation bolts
- Socket wrench
- Double-ended wrench
- Inner hexagon spanner
- Hook wrench
- Screwdriver
- Oil gun

### Optional configuration

- Steady Rest, Follow rest
- DRO
- Chuck cover, Tool post cover, Lead screw cover
- Foot brake
- Live center
- 4 jaw chuck
- Drill chuck and holder
- Face plate
- Back plate
- Quick change tool post
- Taper turning attachment

SPECIFICATIONS	Units	DL6140		DL6150		DL6161		DL6180		DL6280	
		DL6140B	DL6240B	DL6150B	DL6250C	DL6161B	DL6261C	DL6180B	DL6266B	DL6180C	DL6280B
Swing over bed	mm	400mm		500mm		610mm		660mm		800mm	
Swing over cross slide	mm	210mm		300mm		370mm		400mm		540mm	
Swing over gap	mm	-	630	-	720	-	830	-	880	-	1020
Gap length	mm	-	210	-	210	-	210	-	210	-	210
Distance between centers	mm	750/1000/1500/2000/2200/3000/4000									
Spindle bore	mm	52 B:80 C:105									
Spindle bore taper	-										
Spindle speed steps	steps	24		24		24		24		24	
Spindle speed range	rpm	10-1400/16-1400		10-1400/16-1400		10-1400/16-1400		10-1400/16-1400		10-1400/16-1400	
Cross slide travel	mm	320		320		320		320		320	
Top tool post travel	mm	140		140		140		140		140	
Tool size	mm	25*25		25*25		25*25		25*25		25*25	
Longitudinal feeds kinds	kinds	64		64		64		64		64	
Longitudinal feeds range	mm/r	0.028-6.33		0.028-6.33		0.028-6.33		0.028-6.33		0.028-6.33	
Cross feeds range kinds	kinds	64		64		64		64		64	
Cross feeds range	mm/r	0.014-3.16		0.014-3.16		0.014-3.16		0.014-3.16		0.014-3.16	
Longitudinal fast moving	m/min	4		4		4		4		4	
Cross fast moving	m/min	2		2		2		2		2	
Kinds of metric threads	kinds	44		44		44		44		44	
Range of metric threads	mm	1-192		1-192		1-192		1-192		1-192	
Kinds of inch threads	kinds	21		21		21		21		21	
Range of inch threads	T.P.I.	2-24		2-24		2-24		2-24		2-24	
Kinds of threads module	kinds	39		39		39		39		39	
Range of threads module	MP	0.25-48		0.25-48		0.25-48		0.25-48		0.25-48	
Kinds of threads hreads diametral	kinds	37		37		37		37		37	
Range of threads hreads diametral	DP	1-96		1-96		1-96		1-96		1-96	
Tailstock quill diameter	mm	75		75		75		75		75	
Tailstock quill taper	-	MT5		MT5		MT5		MT5		MT5	
Tailstock quill travel	mm	150		150		150		150		150	
Main motor power	kw	7.5		7.5		7.5		11		11	
Coolant motor power	kw	0.09		0.09		0.09		0.09		0.09	
Machine weight	Weight for 750	kg 2000		2100		2200		2300		2400	
	Weight for 1000	kg 2100		2200		2300		2500		2670	
	Weight for 1500	kg 2300		2400		2500		2700		2920	
	Weight for 2000	kg 2600		2700		2800		2900		3170	
	Weight for 2200	kg 2700		2800		3000		3200		3300	
	Weight for 3000	kg 3300		3500		3700		3900		4100	
	Weight for 4000	kg 3800		4000		4200		4420		4600	
Overall dimension	Dimension for 750	mm 2440*1150*1600		2440*1150*1700		2440*1150*1800		2440*1150*1860		2440*1150*2000	
	Dimension for 1000	mm 2650*1150*1600		2650*1150*1700		2650*1150*1800		2650*1150*1860		2650*1150*2000	
	Dimension for 1500	mm 3150*1150*1600		3150*1150*1700		3150*1150*1800		3150*1150*1860		3150*1150*2000	
	Dimension for 2000	mm 3650*1150*1600		3650*1150*1700		3650*1150*1800		3650*1150*1860		3650*1150*2000	
	Dimension for 2200	mm 4030*1150*1600		4030*1150*1700		4030*1150*1800		4030*1150*1860		4030*1150*2000	
	Dimension for 3000	mm 4800*1150*1600		4800*1150*1700		4800*1150*1800		4800*1150*1860		4800*1150*2000	
Dimension for 4000	mm 5680*1150*1600		5680*1150*1700		5680*1150*1800		5680*1150*1860		5680*1150*2000		

NC LATHE

NC LATHE



## Lathe Machine

DW6163E / DW6263E  
DW6180E / DW6280E  
Heavy Duty Lathe

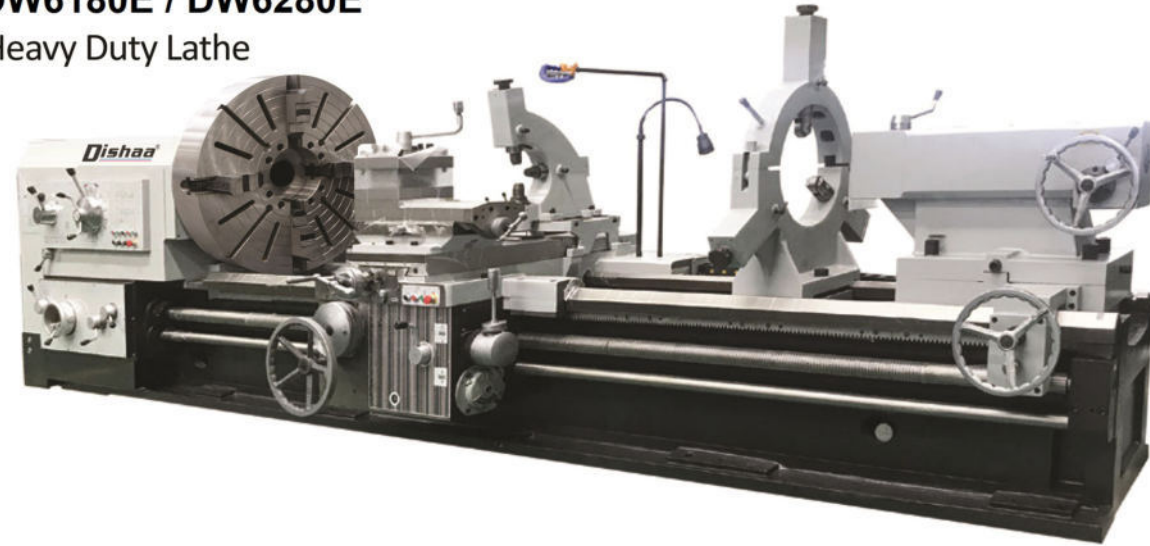

DW6100L / DW6125L  
DW6140L / DW6160L  
Heavy Duty Lathe

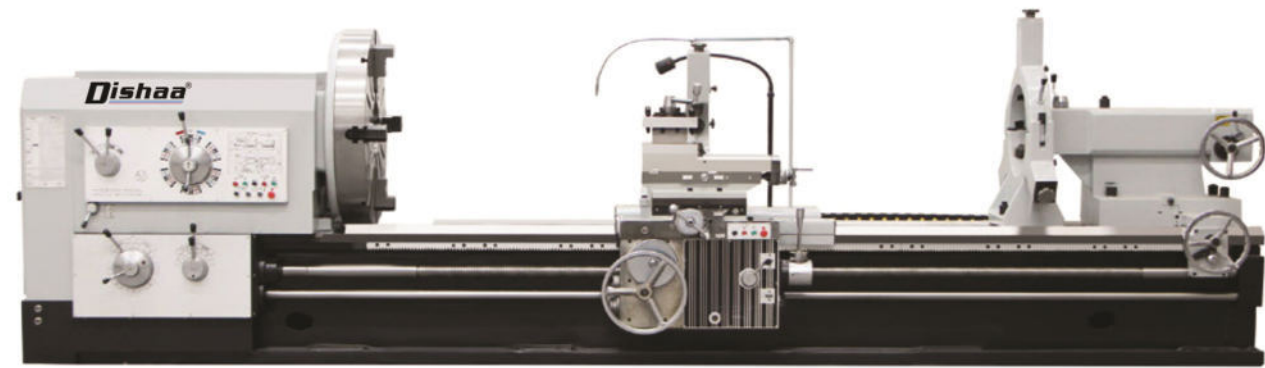

NC LATHE

NC LATHE

SPECIFICATIONS		Units	DW6163E	DW6263E	DW6180E	DW6280E	DW6180F	DW6280F	DW61100F	DW62100F
Swing over bed	mm		630		800		800		1000	
Swing over gap	mm		-	800	-	1000	-	1000	-	1200
Swing over cross slide	mm		350		520		480		680	
Distance between centers	mm				1500/2000/3000/4000/5000/6000					
Guideway width	mm		550		550		600		600	
Max. load capacity	T		3		3		4		4	
Spindle bore	mm		104		104		104		104	
Spindle bore taper	-		Metric120/MT5		Metric120/MT5		Metric120/MT5		Metric120/MT5	
Spindle nose type	-		C11		C11		C11		C11	
Spindle speed steps	steps		18		18		18		18	
Spindle speed range	rpm		7.5-1000		6-800		5.4-720		5.4-720	
Chuck	mm		315 Manual 3-jaw		315 Manual 3-jaw		400 Manual 3-jaw		400 Manual 3-jaw	
Tool size	mm		30*30		30*30		32*32		32*32	
X axis travel	mm		420		420		420		420	
Z axis travel	mm				1350/1850/2850/3850/4850/5850					
X axis feed steps /range	mm/r		64/0.05-12.15		64/0.05-12.15		64/0.05-12.15		64/0.05-12.15	
Z axis feed steps /range	mm/r		64/0.1-24.3		64/0.1-24.3		64/0.1-24.3		64/0.1-24.3	
X axis rapid traverse	mm/min		2300		2300		2300		2300	
Z axis rapid traverse	mm/min		4000		4000		4000		4000	
Metric thread kinds /range	mm		50/1-240		50/1-240		50/1-240		50/1-240	
Inch thread kinds /range	T.P.I		26/14-1		26/14-1		26/14-1		26/14-1	
Module thread kinds /range	mm		53/0.5-120		53/0.5-120		53/0.5-120		53/0.5-120	
DP thread kinds /range	D.P.		24/28-1		24/28-1		24/28-1		24/28-1	
Tailstock quill diameter	mm		100		100		120		120	
Tailstock quill taper	-		MT5		MT5		MT6		MT6	
Tailstock quill travel	mm		250		250		250		300	
Main motor power	kw		11		11		11		11	
Rapid traverse motor power	kw		1.1		1.1		1.1		1.1	
Coolant motor power	kw		0.125		0.125		0.125		0.125	
Machine weight	Weight for 1500	kg	3800		4100		5000		5300	
	Weight for 2000	kg	4200		4500		5400		5700	
	Weight for 3000	kg	4900		5200		6100		6400	
	Weight for 4000	kg	5600		5900		6800		7100	
	Weight for 5000	kg	6300		6600		7500		7800	
Weight for 6000	kg	7000		7300		8200		8500		
Overall dimension	Dimension for 1500	mm	3800*1400*1450		3800*1500*1450		4000*1550*1650		4000*1750*1750	
	Dimension for 2000	mm	4300*1400*1450		4300*1500*1450		4500*1550*1650		4500*1750*1750	
	Dimension for 3000	mm	5300*1400*1450		5300*1500*1450		5500*1550*1650		5500*1750*1750	
	Dimension for 4000	mm	6300*1400*1450		6300*1500*1450		6500*1550*1650		6500*1750*1750	
	Dimension for 5000	mm	7300*1400*1450		7300*1500*1450		7500*1550*1650		7500*1750*1750	
	Dimension for 6000	mm	8300*1400*1450		8300*1500*1450		8500*1550*1650		8500*1750*1750	

SPECIFICATIONS		Units	DW61100L	DW61125L	DW61140L	DW61160L				
Swing over bed	mm		1000		1250		1400		1600	
Swing over cross slide	mm		610		850		1000		1200	
Distance between centers	mm				1500/2000/3000/4000/5000/6000					
Guideway width	mm		755		755		755		755	
Max. load capacity	T		6		6		6		6	
Spindle bore	mm		130		130		130		130	
Spindle bore taper	-		Metric140/MT6		Metric140/MT6		Metric140/MT6		Metric140/MT6	
Spindle nose type	-		A2-15		A2-15		A2-15		A2-15	
Spindle speed steps	steps		21		21		21		21	
Spindle speed range	rpm		3.15-315		3.15-315		3.15-315		3.15-315	
Chuck	mm		1000 Manual 4-jaw		1000 Manual 4-jaw		1000 Manual 4-jaw		1000 Manual 4-jaw	
Tool size	mm		45*45		45*45		45*45		45*45	
X axis travel	mm		620		620		620		620	
Z axis travel	mm				1350/1850/2850/3850/4850/5850					
X axis feed steps /range	mm/r		56/0.05-6		56/0.05-6		56/0.05-6		56/0.05-6	
Z axis feed steps /range	mm/r		56/0.1-12		56/0.1-12		56/0.1-12		56/0.1-12	
X axis rapid traverse	mm/min		1870		1870		1870		1870	
Z axis rapid traverse	mm/min		3740		3740		3740		3740	
Metric thread kinds /range	mm		44/1-120		44/1-120		44/1-120		44/1-120	
Inch thread kinds /range	T.P.I		31/28-3/8		31/28-3/8		31/28-3/8		31/28-3/8	
Module thread kinds /range	mm		45/0.5-60		45/0.5-60		45/0.5-60		45/0.5-60	
DP thread kinds /range	D.P.		30/56-1		30/56-1		30/56-1		30/56-1	
Tailstock quill diameter	mm		φ160		φ160		φ160		φ160	
Tailstock quill taper	-		MT6		MT6		MT6		MT6	
Tailstock quill travel	mm		300		300		300		300	
Main motor power	kw		22		22		22		22	
Rapid traverse motor power	kw		1.5		1.5		1.5		1.5	
Coolant motor power	kw		0.125		0.125		0.125		0.125	
Machine weight	Weight for 1500	kg	9600		10600		11200		13100	
	Weight for 2000	kg	10100		11100		11700		13600	
	Weight for 3000	kg	10700		11700		12300		14200	
	Weight for 4000	kg	11700		12700		13300		15200	
	Weight for 5000	kg	12700		13700		14300		16200	
Weight for 6000	kg	13700		14700		15300		17200		
Overall dimension	Dimension for 1500	mm	4600*2000*1800		4600*2000*1950		4600*2250*2050		4600*2250*2150	
	Dimension for 2000	mm	5100*2000*1800		5100*2000*1950		5100*2250*2050		5100*2250*2150	
	Dimension for 3000	mm	6100*2000*1800		6100*2000*1950		6100*2250*2050		6100*2250*2150	
	Dimension for 4000	mm	7100*2000*1800		7100*2000*1950		7100*2250*2050		7100*2250*2150	
	Dimension for 5000	mm	8100*2000*1800		8100*2000*1950		8100*2250*2050		8100*2250*2150	
	Dimension for 6000	mm	9100*2000*1800		9100*2000*1950		9100*2250*2050		9100*2250*2150	



## Lathe Machine

**D1313 / D1319 / D1322  
D1325 / D1327**

Pipe Threading Lathe Machine

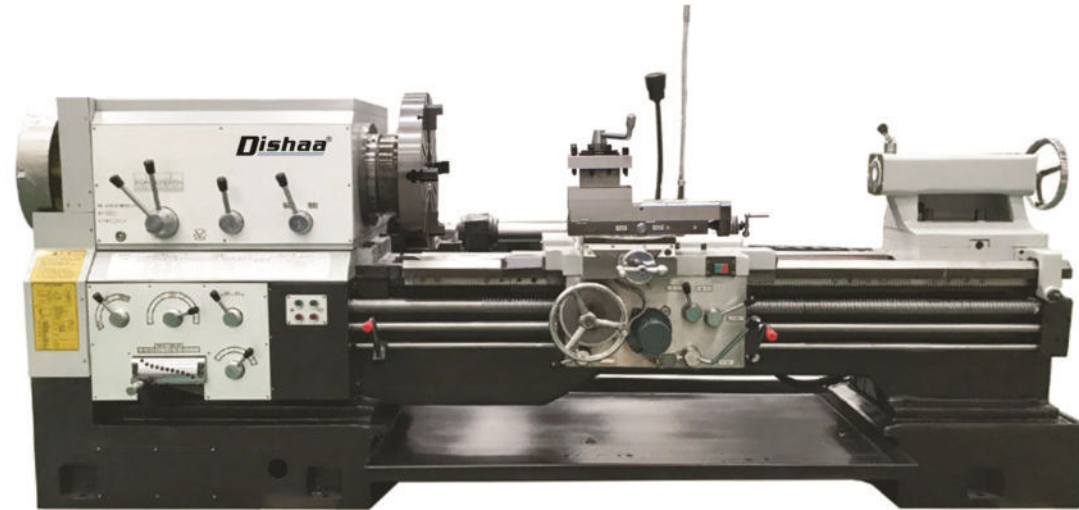

SPECIFICATIONS		Units	D1313	D1319	D1322	D1325	D1327
Swing over bed	mm		630/800	630/800	630/800	800	800
Swing over cross slide	mm		340/520	340/520	340/520	480	480
Distance between centers	mm		1500/3000	1500/3000	1500/3000	1500/3000	1500/3000
Pipe threading range	mm		30-126	50-193	50-220	120-250	130-270
Guideway width	mm		550	550	550	600	600
Max. load capacity	kg		3000	3000	3000	4000	4000
Spindle bore	mm		130	200	230	255	280
Spindle speed steps	steps		18	4	4	4	4
Spindle speed range	rpm		30-650	20-550	20-550	20-420	20-420
Chuck	mm		400	520	520	630	630
			manual/3-jaw	manual/4-jaw	manual/4-jaw	manual/4-jaw	manual/3-jaw
Tool shank size	mm		30*30	32*32	32*32	32*32	32*32
X axis travel	mm		320/420	320/420	320/420	420	420
Z axis travel	mm		1350/2850	1350/2850	1350/2850	1350/2850	1350/2850
X axis feed steps/range	mm/r		22/0.02-0.45	22/0.02-0.45	22/0.02-0.45	22/0.02-0.45	22/0.02-0.45
Z axis feed steps/range	mm/r		26/0.07-1.33	26/0.07-1.33	26/0.07-1.33	26/0.07-1.33	26/0.07-1.33
X axis rapid traverse	mm/min		2300	2300	2300	2300	2300
Z axis rapid traverse	mm/min		4000	4000	4000	4000	4000
Metric thread kinds /range	mm		52/1-24	1-15	1-15	1-15	1-15
Inch thread kinds /range	T.P.I		40/28-2	14-1	14-1	14-1	14-1
Tailstock quill diameter	mm		100	100	100	120	120
Tailstock quill taper	-		MT5	MT5	MT5	MT6	MT6
Tailstock quill travel	mm		250	250	250	250	250
Main motor power	kw		11	11	11	15	15
Rapid traverse motor	kw		0.3	0.3	0.3	1.1	1.1
Coolant motor power	kw		0.125	0.125	0.125	0.125	0.125
Machine weight	Weight for 1500	kg	4000	4300	4500	8000	8000
	Weight for 3000	kg	5200	5500	5700	9000	9000
Overall dimension	Dimension for 1500	mm	3700*1500*1500	3700*1550*1550	3700*1650*1550	4100*1700*1600	4100*1700*1600
	Dimension for 3000	mm	5200*1500*1500	5200*1550*1550	5200*1650*1550	5600*1700*1600	5600*1700*1600

**D1327 / D1332 / D1338  
D1343 / D1350**

Pipe Threading Lathe Machine

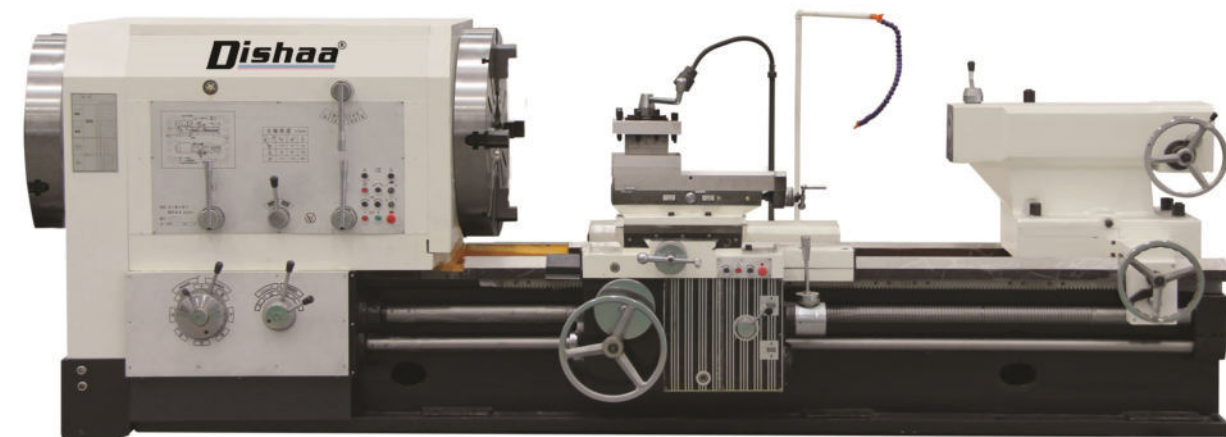

SPECIFICATIONS		Units	D1327	D1332	D1338	D1343	D1350
Swing over bed	mm		1000	1000	1000	1000	1200
Swing over cross slide	mm		610	610	610	610	710
Distance between centers	mm		1500/3000	1500/3000	1500/3000	1500/3000	1500/3000
Pipe threading range	mm		130-270	190-320	190-380	270-430	330-510
Guideway width	mm		755	755	755	755	755
Max. load capacity	kg		6000	6000	6000	6000	6000
Spindle bore	mm		280	330	390	440	520
Spindle speed steps	-		12	9	9	9	9
Spindle speed range	rpm		16-380	7.5-280	6-205	4.9-180	4.9-180
Chuck	mm		800	780	850	1000	1000
			Manual 4-jaw	Electric 4-jaw	Electric 4-jaw	Electric 4-jaw	Electric 4-jaw
Tool size	mm		45*45	45*45	45*45	45*45	45*45
X axis travel	mm		520	520	520	520	520
Z axis travel	mm		1350/2850	1350/2850	1350/2850	1350/2850	1350/2850
X axis feed steps /range	mm/r		40/0.05-1.5	32/0.05-0.75	32/0.05-0.75	32/0.05-0.75	32/0.05-0.75
Z axis feed steps /range	mm/r		40/0.1-3.0	32/0.1-1.5	32/0.1-1.5	32/0.1-1.5	32/0.1-1.5
X axis rapid traverse	mm/min		1870	1870	1870	1870	1870
Z axis rapid traverse	mm/min		3740	3740	3740	3740	3740
Metric thread kinds /range	mm		30/1-30	23/1-15	23/1-15	23/1-15	23/1-15
Inch thread kinds /range	T.P.I		27/28-1	22/28-2	22/28-2	22/28-2	22/28-2
Tailstock quill diameter	mm		160	160	160	160	160
Tailstock quill taper	-		MT6	MT6	MT6	MT6	MT6
Tailstock quill travel	mm		300	300	300	300	300
Main motor power	kw		22	22	22	22	22
Rapid traverse motor	kw		1.5	1.5	1.5	1.5	1.5
Coolant motor power	kw		0.125	0.125	0.125	0.125	0.125
Machine weight	Weight for 1500	kg	10000	11500	12800	13000	15000
	Weight for 3000	kg	11500	13000	14300	14500	16500
Overall dimension	Dimension for 1500	mm	4800*2100*1600	4900*2100*1650	4900*2100*1700	5000*2100*1700	5000*2100*1850
	Dimension for 3000	mm	6300*2100*1600	6400*2100*1650	6400*2100*1700	6500*2100*1700	6500*2100*1850

NC LATHE

NC LATHE



## DCK6152E / DCK6165E / DCK6185E

### CNC Lathe Machine

#### Features

1. Higher stability one-piece machine bed
2. 3-gear spindle speed, step-less in gear
3. Higher rigidity base
4. Wider slide carriage
5. Integrated automatic lubrication system

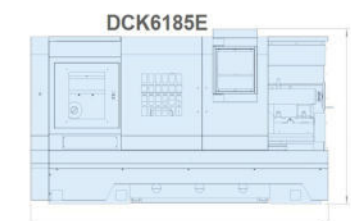
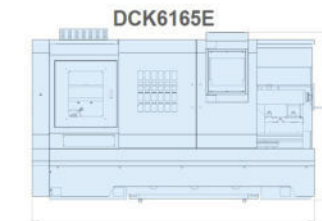
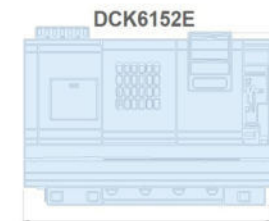

Specifications	Unit	DCK6152E	DCK6165E	DCK6185E
Max. swing dia. over bed	mm	530	650	850
Max. swing dia. over slide	mm	280	375	500
Maximum turning diameter (disc)	mm	520	650	850
Max. work piece length	mm	1000/1500/2000/3000	1000/1500/2000/3000	1000/1500/2000/3000/4000
Maximum turning length	mm	825/1325/1825/2825	900/1400/1900/2900	900/1400/1900/2900/3900
Spindle nose		A2-8	C11	C11
spindle bore	φ/mm	90	105	105
Spindle taper	φ/mm	100/1: 20	120/1: 20	120/1: 20
Spindle speed	r/min	30-150,90-450,315-1600	10-85,40-350,100-850	10-85,40-350,100-850
Spindle shift mode		Three speed mechanical transmission, stepless speed regulation within the gear		
Spindle motor power	KW	7.5	11	11
Chuck type		Manual Chuck	Manual Chuck	Manual Chuck
Chuck size	mm	250	320	400
X axis rapid traverse	m/min	6	4	4
Z axis rapid traverse	m/min	8	5	5
X axis servo motor torque	N.m	7.5	10	10
Z axis servo motor torque	N.m	10/15/22	15/22/30	15/22/30
X axis travel	mm	300	400	450
Z axis travel	mm	1000/1500/2000/3000	1100/1600/2100/3100	1100/1600/2100/3100/4100
Guide way type		Hard rail	Hard rail	Hard rail
Capacity of tool post		4	4	4
Tool shank size	mmxmm	25×25	32×32	32×32
Tail stock quill dia	φ/mm	75	100	100
Tail stock quill travel	mm	150	250	250
Tail stock quill taper		MT5#	MT6#	MT6#
Total rated power	KW	12/12/13	16/18/20	16/18/20
Total rated current	A	26/26/28	36/40/42	36/38/42
Net weight	kg	2900/3150/3500/4300	4000/4400/5000/5800	4200/4600/5200/6000/6700
Machine dimension(L×W×H)	L×W×H(mm)	2600/3100/3600/4800×1600×1670	3300/3800/4300/5300×1900×1900	3300/3800/4300/4800/5800×2000×2000

#### Usage

Controlled by NC system, this machine could process different inner bore, ex-circle, circular conical surface and screw thread, especially suitable for the small and middle-sized shaft and plate work piece from rough processing to finish processing in batch. It has advantages like higher automaticity, simpler programming and higher accuracy.





## DCK6140 / DCK6150 / DVCK6160

### CNC Lathe Machine



#### Features

1. The higher strength base and the widening slide are suitable for heavy cutting
2. Four position electric turret
3. Variable frequency speed
4. Standard configuration: manual chuck
5. Optional configuration: hydraulic chuck

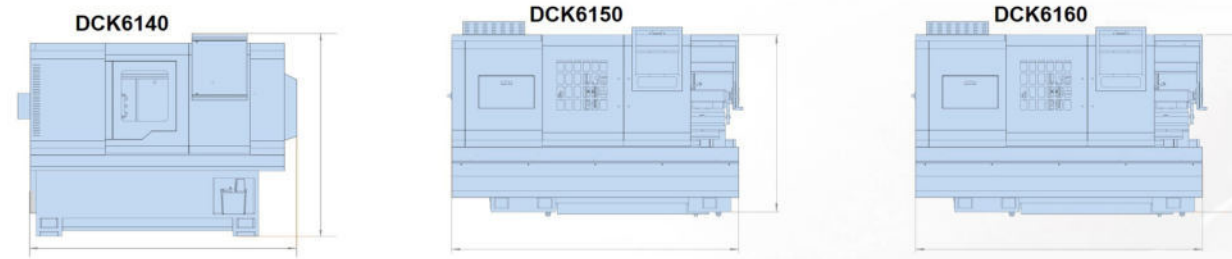

Specifications	Unit	DCK6140	DCK6150	DCK6160
Max. swing dia. over bed	mm	400	500	600
Max. swing dia. over slide	mm	240	250	395
Maximum turning diameter (disc)	mm	400	500	600
Max. work piece length	mm	550/750	1000/1500/2000	1000/1500/2000
Maximum turning length	mm	420/620	850/1350/1850	850/1350/1850
Spindle nose		A2-6/A2-8	A2-8/A2-11	A2-8/A2-11
spindle bore	φ/mm	48/82	82/130	82/130
Spindle taper	φ/mm	Chuck / 90	90/140	90/140
Spindle speed	r/min	150-2500/150-1800	150-1800/150-800	150-1800/150-800
Spindle type		Stepless speed regulation		
Spindle motor power	KW	5.5/7.5	7.5/11	7.5/11
Chuck type		Manual Chuck	Manual Chuck	Manual Chuck
Chuck size	mm	200/250	250/320/380	250/320/380
X axis rapid traverse	m/min	6	6	6
Z axis rapid traverse	m/min	8	8	8
X axis servo motor torque	N.m	4	5/7.5	5/7.5
Z axis servo motor torque	N.m	6	7.5/10/15	7.5/10/15
X axis travel	mm	280	280	325
Z axis travel	mm	550/750	1000/1500/2000	1000/1500/2000
Guide way type		Hard rail	Hard rail	Hard Rail
Capacity of tool post		4	4	4
Tool shank size	mmxmm	20×20	25×25	25×25
Tail stock quill dia	φ/mm	60	75	75
Tail stock quill travel	mm	100	150	150
Tail stock quill taper		MT4#	MT5#	MT5#
Total rated power	KW	8/10	11/12/13	11/12/13
Total rated current	A	17/21	23/26/29	23/26/29
Net weight	kg	1900/2200	2700/3100/3500	2800/3200/3400
Machine dimension(LxWxH)	LxWxH(mm)	2000/2200×1600×1800	2650/3250/3750×1700×1820	2650/3250/3750×1700×1820



#### Usage

Machine tool can automatically process the inside and outside cylinder surface, cone surface, circular arc surface, end face, such as processing, and also can process the single and multiple threads in metric, inch and other standards.



## DCK61100E / DCK61125E

### CNC Lathe Machine

#### Usage

This machine tool is suitable to process the middle and large size work piece in steel, cast iron, non-ferrous metal material. With the feature of big power and high rigidity, this machine is applied to heavy-cut the inner circle, ex-circle, end surface and thread in both metric and English system, and could drill and bore the holes



#### Features

1. Higher stability one-piece machine bed
2. 3-gear sprindle speed, step-less in gear
3. Higher rigidity base
4. Wider slide carriage
5. Integrated automatic lubrication system

DCK61100E

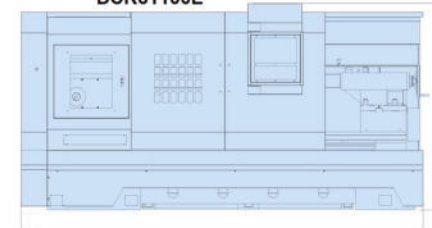

DCK61125E

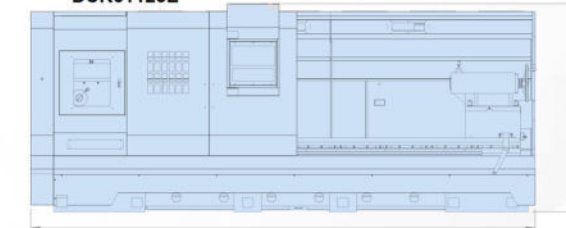

Specifications	Unit	DCK61100E	DCK61125E
Max. swing dia. over bed	mm	1000	1250
Max. swing dia. over slide	mm	650	850
Maximum turning diameter (disc)	mm	1000	1250
Max. work piece length	mm	1500/2000/3000/5000	1500/2000/3000/5000
Maximum turning length	mm	1400/1900/2900	1350/1850/2850
Spindle nose		A2-15	A2-15
spindle bore	Φ/mm	130	130
Spindle taper	Φ/mm	Metric 140/ 1:20	Metric 140/ 1:20
Spindle speed	r/min	10-60,40-240,100-600	10-50,40-120,100-300
Spindle shift mode		Three speed mechanical transmission, stepless speed regulation within the gear	
Spindle motor power	KW	15	22
Chuck type		Manual Chuck	Manual Chuck
Chuck size	mm	500	600
X axis rapid traverse	m/min	4	4
Z axis rapid traverse	m/min	5	5
X axis servo motor torque	N.m	10	15
Z axis servo motor torque	N.m	15/22/30	18/22/30
X axis travel	mm	530	650
Z axis travel	mm	1500/2000/3000	1350/1850/2850
Guide way type		Hard rail	Hard rail
Capacity of tool post		4	4
Tool shank size	mmxmm	40X40	40X40
Tail stock quill dia	Φ/mm	140	160
Tail stock quill travel	mm	250	250
Tail stock quill taper		MT6#	MT6#
Total rated power	KW	22/23/25	29/30/30
Total rated current	A	47/50/54	62/65/65
Net weight	kg	5000/5500/6300	8500/9000/10600
Machine dimension(LxWxH)	LxWxH(mm)	4100/4600/5600×2160×2200	4100/4600/5600×2355×2425



## DH32i / DCK6340 / DCK6340S / DCK6350

### CNC Lathe Machine



#### Features

1. Flat bed/45 degrees slant bed CNC lathe
2. High-precision Taiwan guide rail
3. Chip conveying capacity is large and convenient, customer could choose chip conveying in the right or in the back
4. Spindle unit has two types, the heavy cutting type and the high speed type. The second type is suitable for the high speed and high precision processing.
5. Screw pre-stretching structure
6. Gang type toolas standard
7. Optional turret

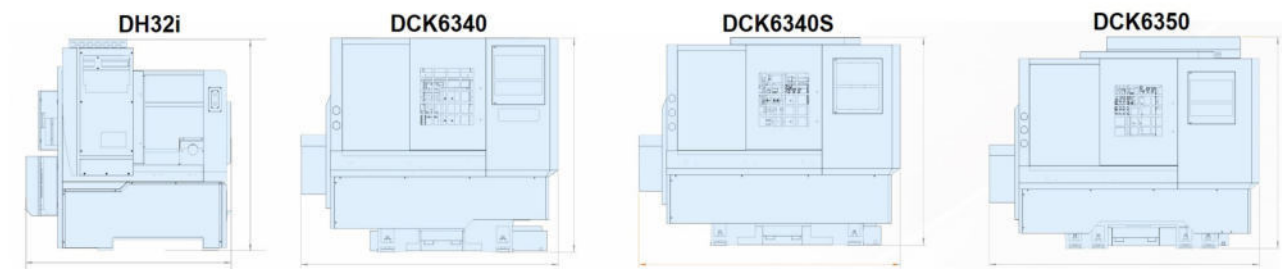

Specifications	Unit	DH32i	DCK6340	DCK6340S	DCK6350
Max. swing dia. over bed	mm	320	400	400	520
Max. swing dia. over slide	mm	70	140	140	220
Max. processing length	mm	280			
Max. bar capacity	mm	39	39/44	39/44	44/54
Max. processing diameter (plate)	mm	320	400	400	500
Spindle nose	GB59001	A2-5	A2-5	A2-5	A2-6
spindle bore	φ/mm	48	48/56	48/56	66
Spindle speed	r/min	50-4000	50-3500	50-3500	50-3000
Spindle shift mode					
Spindle motor power	KW	3.7	5.5	5.5	7.5
Chuck type					
Chuck size	Inch	6	6/8	6/8	10
X axis rapid traverse	m/min	24	24	24	24
Z axis rapid traverse	m/min	24	24	24	24
X axis servo motor torque	N.m	4	6	6	7.5
Z axis servo motor torque	N.m	4	6	6	7.5
X axis travel	mm	280	400	400	500
Z axis travel	mm	330	300	400	500
Guide way type					
Tool post type					
Tool shank size	mm	20x20/Ø25	20x20/Ø25	20x20/Ø25	25x25/Ø32
Total rated power	KW	6	10	12	13
Total rated current	A	13	21	26	28
Net weight	kg	1400	2300	2600	3000
Machine dimension(L×W×H)	(mm)	1620×1420×1700	2200×1530×1780	2390×1530×1780	2500×1620×1890

#### Usage

This machine is mainly used for processing various shaft, disk parts, turning can be all kinds of screw thread, arc, cone and plane of internal and external surface, can satisfy the ferrous and nonferrous metals the speed requirement of high-speed chip. Suitable for cars, motorcycles, electronics, aerospace, military industry and other industries to high efficiency, large quantity and high precision of parts processing. Machining precision can reach level IT6.

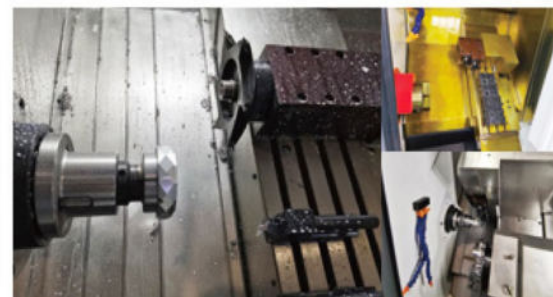



## DCK36A / DCK46A / DCK50A

### CNC Lathe Machine



#### Features

1. Higher accuracy Taiwan linear guideways
2. Higher speed spindle unit
3. Higher rigidity castings
4. Integrated automatic lubrication
5. One-piece casting bed and slant bed
6. Optional power turret

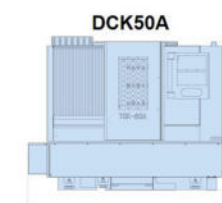
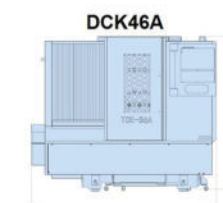
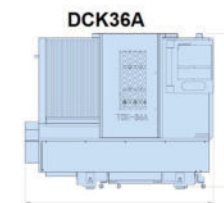

Specifications	Unit	DCK36A	DCK46A	DCK50A
Max. swing dia. over bed	mm	360	460	560
Max. swing dia. over slide	mm	140	260	300
Max. work piece length	mm	300	350	350/500/800/1250
Max. bar capacity	mm	38/44	44	55/75
Max. processing diameter (plate)	mm	360	440/360	440/360
Spindle nose	GB59001	A2-5	A2-5	A2-6/8
spindle bore	φ/mm	48/56	56	66/66/86
Spindle speed	r/min	50-4000	50-3500	0-3000
Spindle shift mode				
Spindle motor power	KW	5.5	7.5	11/11/15
Chuck type				
Chuck size	Inch	6	8	10
X axis rapid traverse	m/min	24	24	24
Z axis rapid traverse	m/min	24	24	24
X axis servo motor torque	N.m	6	7.5	10/15
Z axis servo motor torque	N.m	6	7.5	10/15
X axis travel	mm	185	240	240
Z axis travel	mm	350	400	400/540/860/1300
Guide way type				
turret type				
tool shank size	mm	20X20/Ø25	25x25/Ø32	25X25/Ø32
Tail stock type				
Tail stock quill dia	φ/mm	65	70	70/90
Tail stock quill travel	mm	60	80	80
Tail stock quill taper		MT4#	MT5#	MT5#
Total rated power	KW	9	11	14/18
Total rated current	A	19	23	30
Net weight	kg	2500	3000	3200/3600/4500/5200
Machine dimension(LxWxH)	(mm)	2200×1636×1850	2500×1950×1950	2600/2700/3300/3750×2000×2000

#### Usage

The machine is suitable to process all kinds of small and middle-sized shaft and plate work piece, and could also turn various threads, circle arc, circular cone, inside and outside surface of revolved body. This machine is widely used in sanitary, valve, electrical appliance, instrument, automobile, motorcycle, bearings and so on.



## EDM Drilling Machine

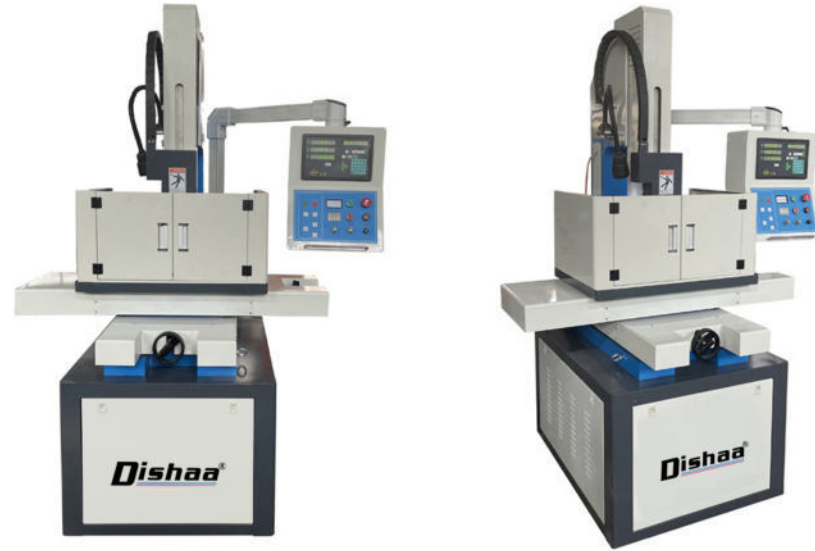

### Features

1. Fast processing speed and low consumption.
2. Auto deep control for blind hole
3. Can drill on oblique and curved surface directly
4. Can use city water as coolant, low cost and no pollution (Pure water is better)

Model	703.30	703.40	703.50	703.63	703.80
Working table size (mm)	320×440	540×780	650×1000	750×1100	980×1350
Stroke X/Y (mm)	300×400	400×500	500×630	630×800	800×1000
Electrode diameter (mm)	Φ0.2-Φ3.0	Φ0.2-Φ3.0	Φ0.2-Φ3.0	Φ0.2-Φ3.0	Φ0.2-Φ3.0
Working stroke Z axis (mm)	300	300	400	500	500
Spindle stroke W axis (mm)	300	400	500	500	500
Distance between working table & guider(mm)	300	350	400	500	500
Power (V/Hz)	single phase 220V 3 Phase 220 230 380 415V /50, 60HZ				
Max. working current (A)	30	30	30	30	30
Capacity of working fluid (L)	25	25	25	25	25
Max.pressure of working fluid (MPa)	7	7	7	7	7
Dimension (L×W×H) (mm)	1060×750×1700	1600×1300×1800	1800×1500×1900	2100×1700×2000	2400×1900×2000
Weight (kg)	600	1100	1600	2200	2800

## EDM Drilling Machine



### Features

1. Steel water protection cover
2. Swivel lever for operating panel
3. Can drill on oblique and curved surface directly
4. Can use city water as coolant, low cost and no pollution (Pure water is better)

Model	703.30A	703.40A	703.50A	703.63A	703.80A
Working table size(mm)	360×480	540×780	650x1000	750×1100	980×1350
Stroke X-Y(mm)	300×400	400×500	500x630	630×800	800×1000
Electrode material	Copper / Brass tube				
Electrode diameter(mm)	Φ0.2-Φ3.0	Φ0.2-Φ3.0	Φ0.2-Φ3.0	Φ0.2-Φ3.0	Φ0.2-Φ3.0
Working stroke Z axis (mm)	300	300	500	500	500
Spindle stroke W axis(mm)	300	400	600	500	500
Spindle rotating speed(mm/min)	20-120	20-120	20-120	500	500
Distance between working table & guider(mm)	300	350	500	500	500
Max. drilling speed (mm/min)	30-60				
Max. working current (A)	30				
Max. consumption power (KVA)	3.5				
Power(V/Hz)	3 Ph, 220V / 380V / 415V, 50/60Hz				
Capacity of water tank(L)	25				
Max.pressure of working fluid(MPa)	7.0				
Dimension(L×W×H)(mm)	1060×750×1700	1600×1300×1800	1950x1500x2100	2100×1700×2000	2400×1900×2000
Weight(kg)	650	1400	1800	2400	3000



## CNC EDM Machine



### Features

- Adaptive discharge machining process.
- High speed lifting and lifting tool height control.
- Spindle fixed point control, discharge gap detection.
- Groove oil level control.
- Fire-proof control, Automatic alarm device.
- Carbon deposit prevention function.
- Automatic measurement.
- Precise edge and plane machining
- Finish the servo system of.
- X Y Z, Panasonic AC servo motor.
- X Y Z, resolution 0.4um, Minimum drive unit 1um.
- Stainless steel edge for wear resistant.

Model		540	650	850	1060
Work table size (length×width) (mm)		850×450	900×550	1150×650	1250×800
X/Y/Z travel	X-axis (mm)	500	650	800	1000
	Y-axis (mm)	400	500	500	600
	Z-axis (mm)	300	350	400	450
Oil groove inside size (mm)		1350×860×500	1650×900×500	1800×1150×600	2000×1300×700
Maximum load of electrode (kg)		50	100	120	150
Max.load on table (kg)		800	2000	3000	3500
Distance from electrode plate to work table (mm)		690-990	460-750	480-880	550-1000
Max. Processing speed (mm <sup>3</sup> /min)		≥500mm <sup>3</sup> /min (graphite-stell); ≥400mm <sup>3</sup> /min (Cu-steel)			
Min. electrode consumption		≤0.1%	≤0.1%	≤0.1%	≤0.1%
Best Roughness (Ra)		Ra 0.1-0.2			
Maximum working current (A)		50	50	50	50
Total input power (KVA)		10	10	10	10
Input power (V)		220/380/415	220/380/415	220/380/415	220/380/415

## CNC EDM Machine



### Features

- XYZ all linear rail to support heavy load and move quickly to ensure precise positioning.
- Marble working table with stainless bracket, no rust.
- Drilling diameter from 0.2mm to 3mm. The maximum depth ratio could be 300:1.
- Capable of drilling all kinds of conductive material, and drill on all kinds shape, such as oblique and curved surface.
- Special program for carbide such as tungsten, fast processing speed and low consumption.

Model	450	630	800	450A
Working table size(mm)	600*420	800*550	1100*720	500*400
Max. load on working table ( kg)	300	500	800	200
Stroke X/Y ( mm)	450*350	630*450	800*630	450*350
Servo stroke Z (mm)	300	350	400	300
Spindle stroke W ( mm)	300	350	400	300
Electrode diameter ( mm)	Φ0.2-Φ3.0	Φ0.2-Φ3.0	Φ0.2-Φ3.0	Φ0.2-Φ3.0
Positioning Accuracy (mm)	±0.01			
Repeated Position Accuracy (mm)	±0.005			
Max. drilling speed	30-60mm/min			
Spindle speed(rpm)	120			
Distance to guider(mm)	350	450	500	350
Max. working current ( A)	30	30	30	30
Voltage (V/Hz)	220/230, 380, 415V / 50-60Hz, 3 Phase			
Capacity of working fluid ( L)	60	60	60	60
Max.pressure of working fluid (MPa)	8	8	8	8
Dimension (L×W×H) (mm)	1600×1200×2100	1800×1400×2100	2100*1700*2200	1300×1200×2000
Weight (kg)	1000	1500	2200	700



## Drilling and Tapping Machine



The electric servo cantilever drilling and tapping machine is suitable for drilling and tapping various machines, molds, and auto parts. The whole machine adopts the suspended manipulator mode, which realizes the integrated interchange of drilling and tapping, which is flexible and convenient. The operation interface adopts touch-screen operation to make drilling and tapping easier and more convenient, which can be operated by any general worker. This machine adopts cantilever drilling and tapping integration, which is fast and convenient, replacing the existing drilling and tapping products in the market.

### Technical Parameters

Model	MR 16A
Drilling Range	Φ3-Φ16
Tapping Range	M5-M20
Collect Qty.	7
Working type	Vertical
Working depth	80(mm)
Working height	400(mm)
Collet	M5-M20
Working radius	850mm
Max. Speed	315rpm
Point angle	no
Voltage	220V
Power	1000W
Weight	270KG

## Electric Tapping Machine



The machine adopts servo drive control, with intelligent torque protection, instead of the traditional lathe, drilling machine or manual tapping limitations. Advances mechanical design, a variety of processes using mold castings, the overall rigidity is strong, durable, non-deformation, beautiful appearance. The high definition touch screen is simple and flexible. It can realize the vertical and horizontal work of complex and heavy workpiece, locate quickly and process accurately. Stepless speed change, manual, automatic, linkage three modes of work, whatever you choose. Automatic mode can effectively control the depth of tapping, without the operation button, automatic control by depth controller. Repeated positioning fast, tapping speed, high production efficiency

### Technical Parameters

ITEM	MR-DS16	MR-DS24	MR-DS30	MR-DS36
Voltage	220V/50HZ	220V/50HZ	220V/50HZ	220V/50HZ
Motor Power	600W	1200W	1200W	1200W
Speed	0-312rpm	0-200rpm	0-180rpm	0-140rpm
Tap Range	M3-M16	M6-M24	M6-M30	M6-M36
ISO COLLET	M3, M4, M5, M6-8, M10, M12, M14, M16	M6-8, M10, M12, M14, M16, M18-20, M22, M24	M6-8, M10, M12, M14, M16, M18-20, M22, M24, M30	M6-8, M10, M12, M14, M16, M18-20, M22, M24, M30, M33, M36
WEIGHT	27KG	44KG	45KG	50KG



## Bench Drilling Machine



### Standard Accessories

- Drill chuck
- Taper sleeve (only MT3 spindle)
- Arbor(only taper hole spindle)
- Drift(only taper hole spindle)
- Wrench

### Technical Parameters

Model	DBD4113	DBD4125	DBD4132
Max. Drilling capacity(mm)	13	25	31.5
Diameter of column(mm)	70	85	85
Spindle travel(mm)	85	110	110
Distance spindle axis to generating line (mm)	180	200	200
Max distance spindle nose to worktable(mm)	390	480	480
Max. Distance spindle nose to base(mm)	570	670	670
Spindle taper(mm)	B16	Mt3	Mt3
Spindle speeds range(r/min)	450-2650	200-2280	150-2270
Spindle speeds series(r/min)	4	9	12
Dimension of worktable surface(mm)	240X240 or Φ300(Optional)	280x280 or Φ360(Optional)	280x280 or Φ360 (Optional)
Dimension of base(mm)	445x270	566x356	566x356
Overall height(mm)	960	1110	1110
Motor(W)	370	750	750
G.W/N.W(kg)	68/65	105/98	105/98
Packing size(cm)	91x51.5x27	108x77x34	108x77x34

## Magnetic Drilling Machine (Multi - Functional)



BJ-2800E      BJ-3800E      BJ-6800E      BJ-7800E      BJ-9800E      BJ-1280E

### Technical Parameters

MODEL	MAX. DRILLING CAPACITY	MAX. ANNULAR CUTTING CAPACITY	MAX. TAPPING CAPACITY	RATED INPUT POWER	MAGNETIC ADHESION	NO-LOAD SPEED	SOFT START	OVERLOAD PROTECTION	STEPLESS SPEED CONTROL	REVERSIBLE	Tool Holder
BJ-2800E	○	28mm	○	1480 W	13000 N	0-680 RPM	●	●	●	○	Weldon Shank 3/4"
BJ-3800E	○	38mm	○	1620 W	14500 N	0-650 RPM	●	●	●	○	Weldon Shank 3/4"
BJ-6800E	23mm	68mm	○	1720 W	15800 N	0-580 RPM	●	●	●	○	2 # Morse
BJ-7800E	23mm	78mm	○	1880 W	16500 N	0-550 RPM	●	●	●	○	2 # Morse
BJ-9800E	28mm	98mm	○	2080 W	16800 N	0-520 RPM	●	●	●	○	3 # Morse
BJ-1280E	28mm	128mm	○	2180 W	17000 N	0-500 RPM	●	●	●	○	3 # Morse

### Ordering Information

Catalog No.	Model No.	Description	N.W(kg)
1535710	BJ-2800E	Magnetic Drill, 110V/50-60Hz	11.8
1544511	BJ-3800E	Magnetic Drill, 110V/50-60Hz	11.8
1535810	BJ-6800E	Magnetic Drill, 110V/50-60Hz	22
1535910	BJ-7800E	Magnetic Drill, 110V/50-60Hz	22
1536010	BJ-9800E	Magnetic Drill, 110V/50-60Hz	24
1536110	BJ-1280E	Magnetic Drill, 110V/50-60Hz	24

Catalog No.	Model No.	Description	N.W(kg)
1535711	BJ-2800E	Magnetic Drill, 220V/50-60Hz	11.8
1544510	BJ-3800E	Magnetic Drill, 220V/50-60Hz	11.8
1535811	BJ-6800E	Magnetic Drill, 220V/50-60Hz	22
1535911	BJ-7800E	Magnetic Drill, 220V/50-60Hz	22
1536011	BJ-9800E	Magnetic Drill, 220V/50-60Hz	24
1536111	BJ-1280E	Magnetic Drill, 220V/50-60Hz	24



Handle      Carbon brush      Instructions      Safety rope      Fuse      Center pin      Wrench      Iron      MT2 adapter      Support block      Water bottle



## Vertical Drilling Machine

### DVD5032/ DVD5040/ DVD5045 Vertical Drilling Machine



SPECIFICATIONS		DVD5032	DVD5040	DVD5045
Max.drilling dia.	mm	32	40	45
Spindle taper	-	MT3/R8	MT4	MT4
Spindle travel	mm	130	130	130
Spindle speed steps	-	6	6	6
Spindle speed range	50Hz rpm	80-1250	80-1250	80-1250
	60Hz rpm	95-1500	95-1500	95-1500
Distance between spindle nose and table surface	mm	725	725	725
Distance between spindle nose and stand table	mm	1125	1125	1125
Distance from spindle axis to column surface	mm	283	283	283
Spindle box travel	mm	250	250	250
Spindle box swivel angle (horizontal/perpendicular)	-	360°/±90°	360°/±90°	360°/±90°
Table size	mm	380*300	380*300	380*300
Table vertical travel	mm	600	600	600
Swivel angle of table horizontal	-	360°	360°	360°
Table tilt angle	-	±45°	±45°	±45°
Stand table size	mm	417*416	417*416	417*416
Main motor power	kw	0.75(1HP)	1.1(1.5HP)	1.5(2HP)
Main motor speed	rpm	1400	1400	1400
Machine weight	kg	470	480	490
Overall dimension	mm	1000*750*1850	1000*750*1850	1000*750*1850

### DVD5032/1 / DVD5040/1 / DVD5045/1 Vertical Drilling Machine



SPECIFICATIONS		Units	DVD5032/1	DVD5040/1	DVD5045/1
Max.drilling dia.	mm		32	40	45
Spindle taper	-		MT3/R8	MT4	MT4
Spindle travel	mm		130	130	130
Spindle speed steps	-		6	6	6
Spindle speed range	50Hz rpm		80-1250	80-1250	80-1250
	60Hz rpm		95-1500	95-1500	95-1500
Spindle feed steps	-		6	6	6
Spindle feed range	mm/r		0.06-0.30	0.06-0.30	0.06-0.30
Distance between spindle nose and table surface	mm		725	725	725
Distance between spindle nose and stand table	mm		1125	1125	1125
Distance from spindle axis to column surface	mm		290	290	290
Spindle box travel	mm		250	250	250
Spindle box swivel angle (horizontal)	-		360°	360°	360°
Table size	mm		380*300	380*300	380*300
Table vertical travel	mm		600	600	600
Swivel angle of table horizontal	-		360°	360°	360°
Table tilt angle	-		±45°	±45°	±45°
Stand table size	mm		417*416	417*416	417*416
Main motor power	kw		0.75(1HP)	1.1(1.5HP)	1.5(2HP)
Main motor speed	rpm		1400	1400	1400
Machine weight	kg		480	490	500
Overall dimension	mm		1000*750*1850	1000*750*1850	1000*750*1850

### DVD5032C/ DVD5040C/ DVD5045C Vertical Drilling Machine

SPECIFICATIONS		Units	DVD5032C	DVD5040C	DVD5045C
Max.drilling dia.	mm		32	40	45
Spindle taper	-		MT3 /R8	MT4	MT4
Spindle travel	mm		130	130	130
Spindle speed steps	-		6	6	6
Spindle speed range	50Hz rpm		80-1250	80-1250	80-1250
	60Hz rpm		95-1500	95-1500	95-1500
Distance between spindle nose and table surface	mm		700	700	700
Distance between spindle nose and stand table	mm		1125	1125	1125
Distance from spindle axis to column surface	mm		283	283	283
Spindle box travel	mm		250	250	250
Spindle box swivel angle (horizontal/perpendicular)	-		360°/±90°	360°/±90°	360°/±90°
Table size	mm		730*210	730*210	730*210
Table travel(X/Y)	mm		500*205	500*205	500*205
Table vertical travel	mm		570	570	570
Stand table size	mm		417*416	417*416	417*416
Main motor power	kw		0.75	1.1	1.5
Main motor speed	rpm		1400	1400	1400
Machine weight	kg		510	520	530
Overall dimension	mm		1000*950*1850	1000*950*1850	1000*950*1850



### DVD5032C/1 / DVD5040C/1 / DVD5045C/1 Vertical Drilling Machine

SPECIFICATIONS		Units	DVD5032C/1	DVD5040C/1	DVD5045C/1
Max.drilling dia.	mm		32	40	45
Spindle taper	-		MT3 /R8	MT4	MT4
Spindle travel	mm		130	130	130
Spindle speed steps	-		6	6	6
Spindle speed range	50Hz rpm		80-1250	80-1250	80-1250
	60Hz rpm		95-1500	95-1500	95-1500
Spindle feed steps	-		6	6	6
Spindle feed range	mm/r		0.06-0.30	0.06-0.30	0.06-0.30
Distance between spindle nose and table surface	mm		700	700	700
Distance between spindle nose and stand table	mm		1125	1125	1125
Distance from spindle axis to column surface	mm		290	290	290
Spindle box travel	mm		250	250	250
Spindle box swivel angle (horizontal/perpendicular)	-		360°/±90°	360°/±90°	360°/±90°
Table size	mm		730*210	730*210	730*210
Table travel(X/Y)	mm		500*205	500*205	500*205
Table vertical travel	mm		570	570	570
Stand table size	mm		417*416	417*416	417*416
Main motor power	kw		0.75	1.1	1.5
Main motor speed	rpm		1400	1400	1400
Machine weight	kg		520	530	540
Overall dimension	mm		1000*950*1850	1000*950*1850	1000*950*1850





## Vertical Drilling Machine

**DVD5025 / DVD5025B /  
DVD5030A / DVD5035A**

Vertical Drilling Machine



SPECIFICATIONS	Units	DVD5025B	DVD5025	DVD5030A	DVD5035A
Max.drilling dia.	mm	25	25	30	35
Diameter of column	mm	100	100	120	140
Spindle travel	mm	150	150	135	160
Distance between spindle nose and table surface	mm	-	630	550	590
Distance between spindle nose and stand table	mm	550	1670	1100	1150
Distance from spindle axis to column surface	mm	225	225	320	330
Spindle taper	-	MT3	MT3	MT4	MT4
Spindle speed range	rpm	100-2900	100-2900	125-3030	125-3030
Spindle speeds steps	-	8	8	12	12
Spindle feed	mm/r	0.07-0.40	0.07-0.40	0.1-0.3	0.1-0.3
Spindle feed steps	-	4	4	3	3
Table size	mm	-	440	500*420	500*440
Table travel	mm	-	560	520	560
Stand table size	mm	690*500	690*500	645*455	645*455
Main motor power	kw	0.75/1.1	0.75/1.1	1.1/1.5	1.1/1.5
Coolant motor power	w	40	40	40	40
Machine weight	kg	235	300	410	430
Overall dimension	mm	780*520*1170	700*560*1820	875*510*2100	875*510*2150

**DVD5040A / DVD5050A**

Vertical Drilling Machine



SPECIFICATIONS	Units	DVD5040A	DVD5050A
Max.drilling dia.	mm	40	50
Diameter of column	mm	160	180
Spindle travel	mm	200	240
Distance between spindle nose and table surface	mm	590	570
Distance between spindle nose and stand table	mm	1175	1160
Distance from spindle axis to column surface	mm	360	360
Spindle taper	-	MT4	MT4/MT5
Spindle speed range	rpm	52-1400	42-2050
Spindle speeds steps	-	12	12
Spindle feed	mm/r	0.1-0.4	0.07-0.4
Spindle feed steps	-	3	4
Table size	mm	580*460	550*470
Table travel	mm	585	550
Stand table size	mm	730*500	450*440
Main motor power	kw	2.2	2.2/2.8
Coolant motor power	w	40	40
Machine weight	kg	650	1045
Overall dimension	mm	940*680*2405	1080*620*2450



## Vertical Drilling Machine

DVD5125 / DVD5132 /  
DVD5140B / DVD5150B

Vertical Drilling Machine

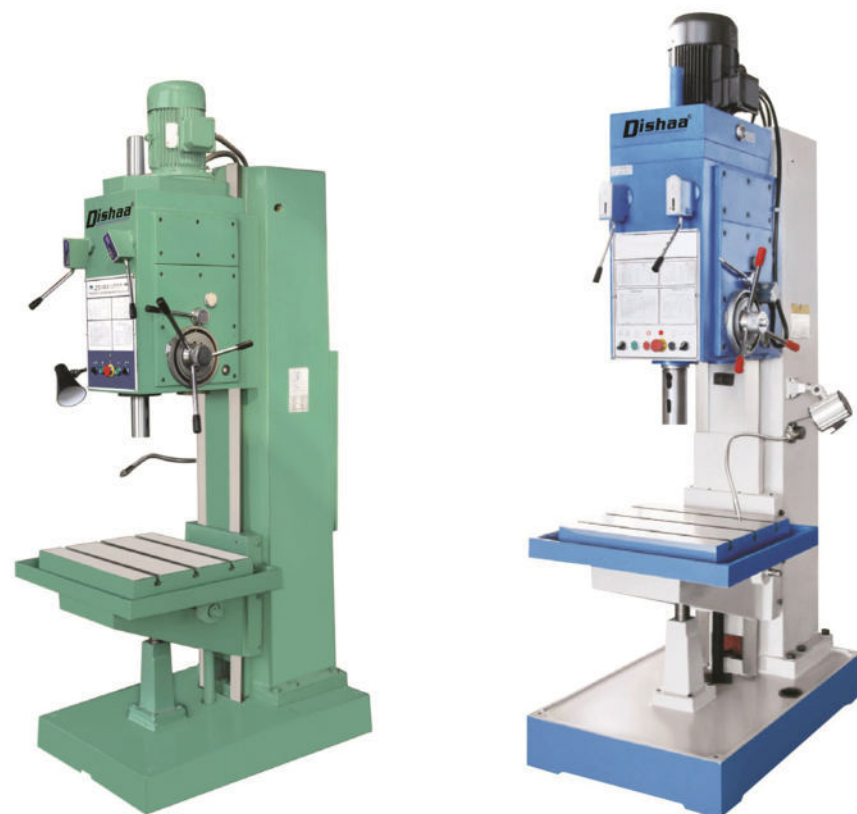

SPECIFICATIONS	Units	DVD5125	DVD5132	DVD5140B	DVD5150B
Max.drilling dia.	mm	25	32	40	50
Max.feed resistance	N	9000	12000	16000	16000
Max. allowable torque	N.m	160	200	350	350
Spindle taper	-	MT3	MT4	MT4	MT5
Spindle travel	mm	200	200	250	250
Distance between spindle nose and table surface	mm	710	710	750	750
Distance from spindle axis to column surface	mm	280	280	350	350
Spindle box travel	mm	200	200	200	200
Spindle speed range	rpm	50-2000	50-2000	31.5-1400	31.5-1400
Spindle speeds steps	step	9	9	12	12
Spindle feed range	mm/r	0.056-1.8	0.056-1.8	0.056-1.8	0.056-1.8
Spindle feed steps	step	9	9	9	9
Table size	mm	550*400	550*400	560*480	560*480
Table travel	mm	310	310	300	300
Main motor power	kw	2.2	2.2	3	3
Coolant motor power	kw	0.09	0.09	0.09	0.09
Machine weight	kg	1100	1150	1300	1350
Overall dimension	mm	980*807*2302	980*807*2302	1090*900*2530	1090*900*2530

DVD5140B/1 / DVD5150B/1 /  
DVD5163 / DVD51100

Vertical Drilling Machine

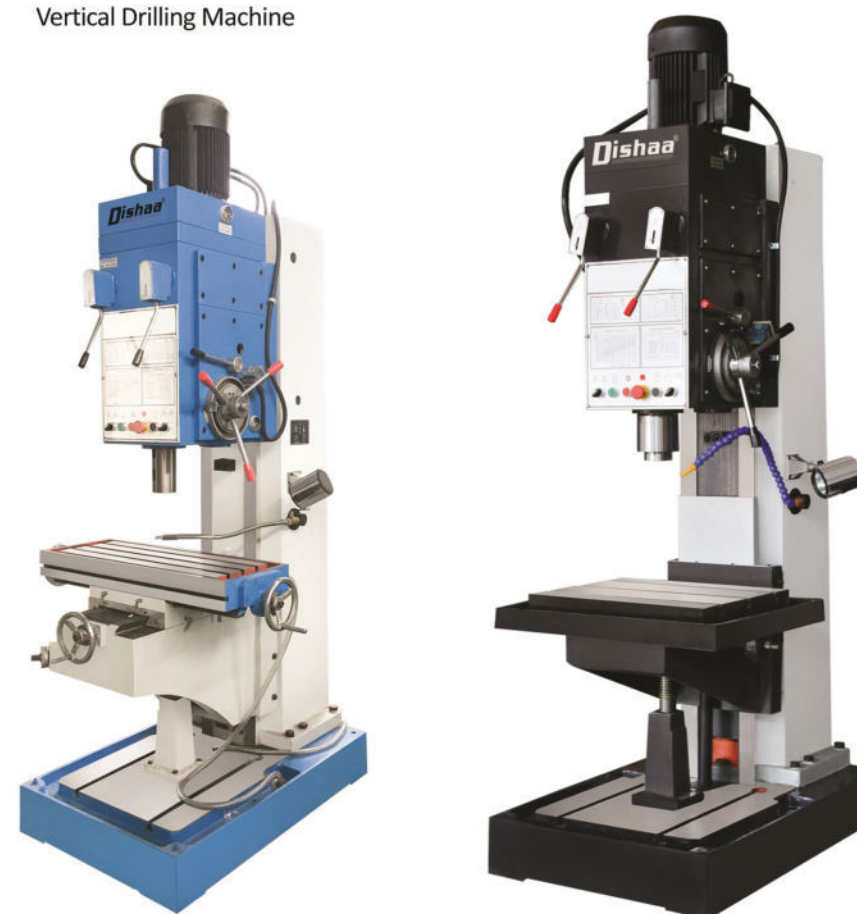

SPECIFICATIONS	Units	DVD5140B/1	DVD5150B/1	DVD5163	DVD5180	DVD51100
Max.drilling dia.	mm	40	50	63	80	100
Max.feed resistance	N	16000	16000	30000	30000	45000
Max. allowable torque	N.m	350	350	800	1000	1150
Spindle taper	-	MT4	MT5	MT5	MT6	MT6
Spindle travel	mm	250	250	250	250	310
Distance between spindle nose and table surface	mm	750	750	800	800	850
Distance from spindle axis to column surface	mm	335	335	375	375	480
Spindle box travel	mm	200	200	250	250	200
Spindle speed range	rpm	31.5-1400	31.5-1400	40-570	40-570	26-320
Spindle speeds steps	step	12	12	9	9	6
Spindle feed range	mm/r	0.056-1.8	0.056-1.8	0.1-0.78	0.1-0.78	0.096-0.717
Spindle feed steps	step	9	9	6	6	6
Table size	mm	800*320	800*320	650*550	650*550	760*650
Table travel(X/Y)	mm	440/300	440/300	-	-	-
Table vertical travel	mm	300	300	300	300	300
Main motor power	kw	3	3	5.5	5.5	7.5
Coolant motor power	kw	0.09	0.09	0.09	0.09	0.09
Machine weight	kg	1300	1350	2500	2600	3500
Overall dimension	mm	1090*905*2530	1090*905*2530	1455*965*2790	1455*965*2790	1465*970*3170



## Radial Drilling Machine (Mechanical Clamping)



### DRM3132 / DRM3732

Universal Radial Drilling Machine

SPECIFICATIONS	Units	DRM3132	DRM3732
Max.drilling dia.	mm	32	32
Distance between spindle nose and table surface	mm	25-870	25-870
Distance from spindle axis to column surface	mm	315-815	315-815
Spindle travel	mm	130	130
Spindle taper	-	MT3/MT4	MT3/MT4
Spindle speed range	rpm	173-960	173-960
Spindle speed steps	-	4	4
Main motor power	kw	1.5	1.5
Machine weight	kg	850	870
Overall dimension	mm	1800*700*2044	1800*700*2044

### DRM3040x13

Radial Drilling Machine



### DRM3035x10

Radial Drilling Machine



### DRM3040X10

Radial Drilling Machine



### DRM3032x7 DRM3032x7P

"P"with Collant Systems  
Radial Drilling Machine

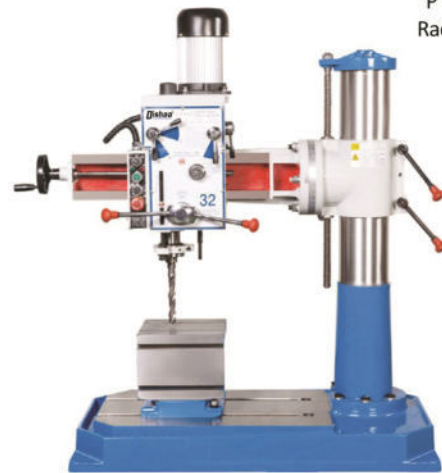

### DRM3032x10

Radial Drilling Machine



#### Main features

- Mechanical transmission
- Mechanical clamping
- Mechanical change speed
- Automatic feed

SPECIFICATIONS	Units	DRM3022x7 / DRM3032x10	DRM3032X10
Max.drilling dia.	mm	32	32
Distance between spindle nose and table surface	mm	275-680	330-1060
Distance from spindle axis to column surface	mm	300-700	200-910
Spindle travel	mm	130	120
Spindle taper	-	MT3	MT4
Spindle speed range	rpm	100-1600	108-1000
Spindle speed steps	-	8	6
Spindle feeding range	rpm	0.08-0.23	0.10-0.25
Spindle feeding steps	-	3	3
Main motor power	kw	0.75/1.1	1.5/2.2
Lifting motor power	kw	-	0.55
Machine weight	kg	415/540	1080
Overall dimension	mm	1220*620*1280 1270*690*1370	1400*660*2060

SPECIFICATIONS	Units	DRM3035x10	DRM3040x10	DRM3040X13
Max.drilling dia.	mm	35	40	40
Distance between spindle nose and table surface	mm	300-1000	360-1000	360-1300
Distance from spindle axis to column surface	mm	260-1200	260-1200	260-1200
Spindle travel	mm	200	200	200
Spindle speed range	rpm	75-1220	75-1220	75-1220
Spindle speed steps	-	6	6	6
Spindle feed range	-	0.10-0.22	0.10-0.22	0.10-0.22
Spindle feed steps	-	3	3	3
Main motor power	kw	2.2	2.2	2.2
Machine weight	kg	1200	1500	1700
Overall dimension	mm	1500*750*2150	1500*750*2300	1800*750*2300



## Radial Drilling Machine (Mechanical Clamping)



**DRM3040x11**  
Radial Drilling Machine



**DRM3040x11B**  
Radial Drilling Machine

**Main features**

- Automatic tool retraction
- Strengthening spindle
- Drill fixed depth



**DRM3040x14**  
Radial Drilling Machine



**DRM3040x14B**  
Radial Drilling Machine

**Main features**

- Automatic tool retraction
- Strengthening spindle
- Drill fixed depth

**DRM3040x14 / II**  
Radial Drilling Machine

**DRM3040x11 / I**  
Radial Drilling Machine

**Main features**

- Centralized mechanical change speed



**DRM3040x11 / II**  
Radial Drilling Machine



**DRM3040x14 / I**  
Radial Drilling Machine

**Main features**

- Centralized mechanical change speed
- Hydraulic clamping column and rocker arm



**Main features**

- Electronic control column clamping

SPECIFICATIONS	Units	DRM3040x11	DRM3040x11B	DRM3040x11/I	DRM3040x11/II
Max.drilling dia.	mm	40	40	40	40
Distance between spindle nose and table surface	mm	320-1200	170-1100	170-1100	220-1180
Distance from spindle axis to column surface	mm	330-1100	330-1050	330-1050	340-1150
Spindle travel	mm	200	250	260	270
Spindle taper	-	MT4	MT4	MT4	4
Spindle speed range	rpm	75-1200	75-1200	40-1896	40-1250
Spindle speed steps	-	6	6	12	6
Spindle feed range	rpm	0.10-0.25	0.10-0.25	0.13-0.54	0.10-0.25
Spindle feed steps	-	3	3	4	3
Main motor power	kw	2.2	2.2	2.2	2.2
Lifting motor power	kw	0.75	0.75	0.75	0.75
Machine weight	kg	1600	1600	1600	1600
Overall dimension	mm	1500*705*2200	1500*705*2200	1655*720*2200	1500*720*2200

SPECIFICATIONS	Units	DRM3040x14	DRM3040x14B	DRM3040x14/I	DRM3040x14/II
Max.drilling dia.	mm	40	40	40	40
Distance between spindle nose and table surface	mm	380-1240	380-1280	280-1210	260-1050
Distance from spindle axis to column surface	mm	320-1370	300-1350	370-1370	360-1400
Spindle travel	mm	200	250	260	270
Spindle taper	-	MT4	MT4	MT4	MT4
Spindle speed range	rpm	75-1200	75-1200	40-1896	40-1250
Spindle speed steps	-	6	6	12	6
Spindle feed range	rpm	0.10-0.25	0.10-0.25	0.13-0.54	0.10-0.25
Spindle feed steps	-	3	3	4	3
Main motor power	kw	2.2	2.2	2.2	2.2
Lifting motor power	kw	1.5	1.5	1.5	1.5
Machine weight	kg	2000	2000	2000	2200
Overall dimension	mm	1800*810*2300	1800*810*2300	2053*820*2483	1800*810*2200



## Radial Drilling Machine (Mechanical Clamping)

RADIAL DRILLING

RADIAL DRILLING

**DRM3050x11**  
Radial Drilling Machine

- Main features**
- Mechanical transmission
  - Mechanical clamping
  - Mechanical change speed
  - Automatic lifting
  - Automatic feed



- Main features**
- Mechanical transmission
  - Mechanical clamping
  - Mechanical change speed
  - Automatic tool retraction

**DRM3050x11B**  
Radial Drilling Machine



**DRM3050x14**  
Radial Drilling Machine

- Main features**
- Mechanical transmission
  - Mechanical clamping
  - Mechanical change speed
  - Automatic feed
  - Automatic lifting



**DRM3050x14 / II**  
Radial Drilling Machine



**DRM3050x14B**  
Radial Drilling Machine

- Main features**
- Mechanical transmission
  - Mechanical clamping
  - Mechanical change speed
  - Automatic tool retraction



SPECIFICATIONS	Units	DRM3050x11	DRM3050x11B
Max.drilling dia.	mm	50	50
Distance between spindle nose and table surface	mm	260-1150	130-1050
Distance from spindle axis to column surface	mm	360-1050	370-1020
Spindle travel	mm	200	250
Spindle taper	-	MT5	MT5
Spindle speed range	rpm	78-1100	35-1400
Spindle speed steps	-	6	12
Spindle feed range	rpm	0.10-0.56	0.054-1.723
Spindle feed steps	-	6	9
Main motor power	kw	4	4
Lifting motor power	kw	0.75	0.75
Machine weight	kg	1700	2200
Overall dimension	mm	1550*705*2250	1750*800*2250

SPECIFICATIONS	Units	DRM3050x14	DRM3050x14B	DRM3050x14/II
Max.drilling dia.	mm	50	50	50
Distance between spindle nose and table surface	mm	300-1200	225-1170	300-1210
Distance from spindle axis to column surface	mm	350-1310	350-1340	330-1310
Spindle travel	mm	200	250	200
Spindle taper	-	MT5	MT5	MT5
Spindle speed range	rpm	135-1100	35-1400	78-1100
Spindle speed steps	-	6	12	6
Spindle feed range	rpm	0.10-0.56	0.054-1.723	0.10-0.56
Spindle feed steps	-	6	9	6
Main motor power	kw	4	4	4
Lifting motor power	kw	1.5	1.5	1.5
Machine weight	kg	2000	2400	2300
Overall dimension	mm	1950*810*2450	2050*810*2450	2170*950*2450



## Radial Drilling Machine (Mechanical Clamping)

## Radial Drilling Machine (Hydraulic Clamping)

**DRH3050x16**  
Radial Drilling Machine



**DRH3050x16B**  
Radial Drilling Machine



**Main features**

- Automatic tool retraction
- Strengthening spindle
- Drill fixed depth

**DRH3050x16/ I**  
Radial Drilling Machine



**Main features**

- Centralized mechanical change speed
- Hydraulic clamping column and rocker arm

**DRH3050x16/ II**  
Radial Drilling Machine



- Electronic control column clamping



**DRH3040x14**  
Radial Drilling Machine

**Main features**

- Hydraulic transmission
- Hydraulic clamping
- Hydraulic change speed
- Hydraulic pre-selection

**DRH3050x16**  
Radial Drilling Machine

**Main features**

- Hydraulic transmission
- Hydraulic clamping
- Hydraulic change speed
- Hydraulic pre-selection



SPECIFICATIONS	Units	DRH3050x16	DRH3050x16B	DRH3050x16/ I	DRH3050x16/II
Max.drilling dia.	mm	50	50	50	50
Distance between spindle nose and table surface	mm	330-1200	200-1110	200-1140	330-1210
Distance from spindle axis to column surface	mm	350-1520	350-1500	370-1520	350-1570
Spindle travel	mm	210	250	310	210
Spindle taper	-	MT5	MT5	MT5	MT5
Spindle speed range	rpm	78-1100	35-1400	29-1366	78-1100
Spindle speed steps	-	6	12	12	6
Spindle feed range	rpm	0.10-0.56	0.054-1.723	0.1-0.4	0.1-0.56
Spindle feed steps	-	6	9	4	6
Main motor power	kw	4	4	4	4
Lifting motor power	kw	1.5	1.5	1.5	1.5
Machine weight	kg	2500	2400	3000	2500
Overall dimension	mm	2170*950*2450	2050*800*2450	2200*900*2550	2170*950*2450

SPECIFICATIONS	Units	DRH3040x14	DRH3050X16
Max.drilling dia.	mm	40	50
Distance between spindle nose and table surface	mm	260-1210	320-1220
Distance from spindle axis to column surface	mm	350-1370	370-1620
Spindle travel	mm	270	315
Spindle taper	-	MT4	MT5
Spindle speed range	rpm	32-2500	25-2000
Spindle speed steps	-	16	16
Spindle feed range	rpm	0.10-1.25	0.04-3.2
Spindle feed steps	-	8	16
Main motor power	kw	3	4
Lifting motor power	kw	0.75	1.5
Machine meight	kg	2200	3500
Overall dimension	mm	2053*820*2483	2500*1060*2800



## Radial Drilling Machine (Hydraulic Clamping)



**DRH3063x20**  
Radial Drilling Machine

**Main features**

- Hydraulic transmission
- Hydraulic clamping
- Hydraulic change speed
- Hydraulic pre-selection



**DRH3080x20A**  
**DRH3080x25A**  
Radial Drilling Machine

**Main features**

- Hydraulic transmission
- Hydraulic clamping
- Hydraulic change speed
- Hydraulic pre-selection

SPECIFICATIONS	Units	DRH3063x20	DRH3080x20A	DRH3080x25A
Max.drilling dia.	mm	63	80	80
Distance between spindle nose and table surface	mm	290-1540	350-1585	350-1585
Distance from spindle axis to column surface	mm	430-1930	500-2070	500-2570
Spindle travel	mm	400	400	400
Spindle taper	-	MT5	MT6	MT6
Spindle speed range	rpm	16-1250	16-1250	16-1250
Spindle speed steps	-	16	16	16
Spindle feed range	rpm	0.04-3.20	0.04-3.20	0.04-3.20
Spindle feed steps	-	16	16	16
Main motor power	kw	5.5	7.5	7.5
Lifting motor power	kw	1.5	1.5	1.5
Machine weight	kg	6500	7000	9500
Overall dimension	mm	3000*1250*3300	3000*1250*3300	3500*1450*3300

**DRH30100x31**  
**DRH30125x40**  
Radial Drilling Machine

**Main features**

- Hydraulic transmission
- Hydraulic clamping
- Hydraulic change speed
- Hydraulic pre-selection

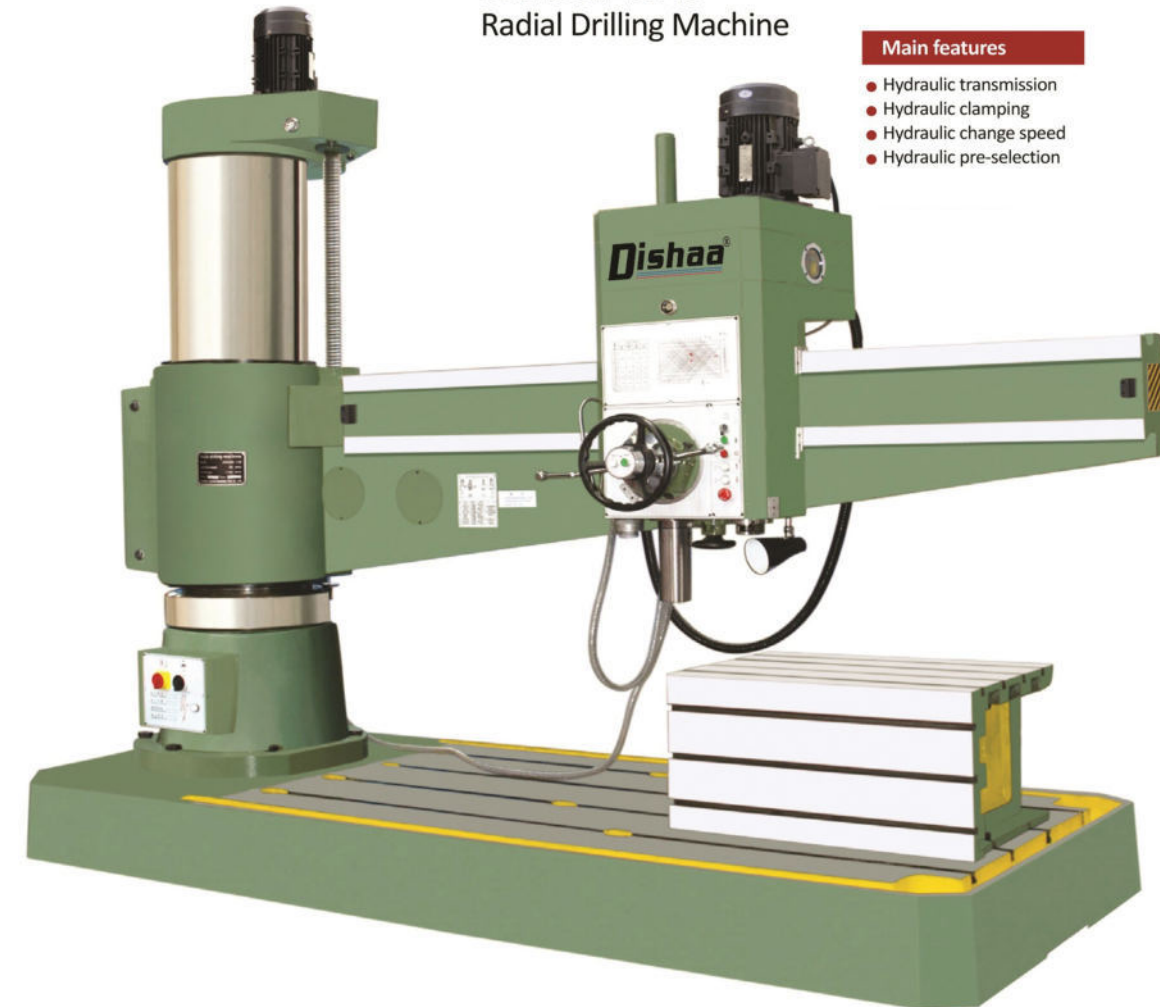

SPECIFICATIONS	Units	DRH30100x31	DRH30125x40
Max.drilling dia.	mm	100	125
Distance between spindle nose and table surface	mm	750-2500	750-2500
Distance from spindle axis to column surface	mm	570-3150	600-4000
Spindle travel	mm	500	560
Spindle taper	-	MT6	Metric 80
Spindle speed range	rpm	8-1000	6.3-800
Spindle speed steps	-	22	22
Spindle feed range	rpm	0.06-3.2	0.06-3.2
Spindle feed steps	-	16	16
Main motor power	kw	15	18.5
Rocker arm lift travel	mm	1250	1250
Machine weight	kg	20000	28500
Overall dimension	mm	4660*1630*4525	4960*2000*4780



## Drilling & Milling Machine

### DDM7020 / DDM7032 DDM7040 / DDM7045

Drilling And Milling Machine

#### Main features

- Belt-driven and round column

#### Standard Accessories

- Allen wrench
- Wedge
- Tie rod

#### Optional Accessories

- Drill chuck
- Milling cutter holder
- Mill chuck
- Power feed attachment
- Auto-tapping electrical
- Paraller vise
- Working lamp
- Coolant system
- Machine stand and chip tray
- Clamping kits(58pcs)
- Rortary table



SPECIFICATIONS	Units	DDM7020	DDM7032	DDM7040	DDM7045
Max.drilling dia.	mm	20	32	40	45
Max.face milling capacity	mm	63	63	80	80
Max.end milling capacity	mm	20	20	32	32
Distance between spindle nose and table surface	mm	435	450	450	450
Distance from spindle axis to column surface	mm	181.5	203.5	203.5	203.5
Spindle travel	mm	80	130	130	130
Spindle taper	-	M.T.3 or R8	M.T.3 or R8	M.T.4 or R8	M.T.4 or R8
Spindle speed steps	-	12	12	12	12
Spindle speed	r.p.m	50Hz 100-2200	80-2080	80-2080	80-2080
		60Hz 120-2640	100-2500	100-2500	100-2500
Swivel angle of headstock (horizontal)	-	360	360	360	360
Table size	mm	520*160	800*240	800*240	800*240
Table travel	mm	290*140	500*175	500*175	500*175
Main motor Power	kw	0.55	0.75	1.1	1.5
Machine weight	kg	190	330	333	335
Overall dimension	mm	620*750*1700	1020*820*1860	1020*820*1860	1020*820*1860
Loading amount	-	48pcs/20'container	28pcs/20'container	28pcs/20'container	28pcs/20'container

### DDM7020G / DDM7032G DDM7040G / DDM7045G

Drilling And Milling Machine

#### Main features

- Gear-driven and round column

#### Standard Accessories

- Allen wrench
- Wedge
- Tie rod

#### Optional Accessories

- Drill chuck
- Milling cutter holder
- Mill chuck
- Power feed attachment
- Auto-tapping electrical
- Paraller vise
- Working lamp
- Coolant system
- Machine stand and chip tray
- Clamping kits(58pcs)
- Rortary table
- 2-Axis DRO,3-Axis DRO



SPECIFICATIONS	Units	DDM7020G	DDM7032G	DDM7040G	DDM7045G
Max.drilling dia.	mm	20	32	40	45
Max.face milling dia.	mm	63	63	80	80
Max.end milling dia.	mm	20	20	32	32
Distance between spindle nose and table surface	mm	439	440	440	440
Distance from spindle axis to column surface	mm	197.5	272.5	272.5	272.5
Spindle travel	mm	80	130	130	130
Spindle taper	-	M.T.3 or R8	M.T.3 or R8	M.T.4 or R8	M.T.4 or R8
Spindle speed steps	-	6	6	6	6
Spindle speed	r.p.m	50Hz 95-1420	80-1250	80-2080	80-1250
		60Hz 115-1700	95-1500	95-1500	95-1500
Swivel angle of headstock (horizontal)	-	360/±90	360/±90	360/±90	360/±90
Table size	mm	520*160	800*240	800*240	800*240
Table travel	mm	290*140	500*175	500*175	500*175
Main motor Power	kw	0.55	0.75	1.1	1.5
Machine weight	kg	190	365	368	370
Overall dimension	mm	680*750*1700	770*880*1860	770*880*1860	770*880*1860
Loading amount	-	48pcs/20'container	36pcs/20'container	36pcs/20'container	36pcs/20'container



## Drilling & Milling Machine

### DDM7025FG / DDM7032FG DDM7040FG / DDM7045FG

Drilling And Milling Machine

#### Main features

- Gear-driven and round column

#### Standard Accessories

- Allen wrench
- Wedge
- Tie rod

#### Optional Accessories

- Drill chuck
- Milling cutter holder
- Mill chuck
- Power feed attachment
- Auto-tapping electrical
- Paraller vise
- Working lamp
- Coolant system
- Machine stand and chip tray
- Clamping kits(58pcs)
- Rortary table
- 2-Axis DRO,3-Axis DRO



SPECIFICATIONS	Units	DDM7025FG	DDM7032FG	DDM7040FG	DDM7045FG
Max.drilling dia.	mm	25	32	40	45
Max.face milling capacity	mm	63	63	80	80
Max.end milling capacity	mm	20	20	32	32
Distance between spindle nose and table surface	mm	445	450	450	450
Distance from spindle axis to column surface	mm	203	260	260	260
Spindle travel	mm	80	130	130	130
Spindle taper	-	M.T.3 or R8	M.T.3 or R8	M.T.4 or R8	M.T.4 or R8
Spindle speed steps	-	6	6	6	6
Spindle speed	r.p.m	50Hz 95-1420	80-1250	80-1250	80-1250
		60Hz 115-1700	95-1500	95-1500	95-1500
Swivel angle of headstock (horizontal)	-	±90	±90	±90	±90
Table size	mm	520*160	800*240	800*240	800*240
Table travel	mm	290*140	500*175	500*175	500*175
Main motor Power	kw	0.37	0.75	1.1	1.5
Machine weight	kg	240	370	373	375
Overall dimension	mm	680*750*1700	770*880*1860	770*880*1860	770*880*1860
Loading amount	-	48pcs/20' container	36pcs/20' container	36pcs/20' container	36pcs/20' container

### DDM7032FG/1 DDM7040FG/1 DDM7045FG/1

Drilling And Milling Machine

#### Main features

- Gear-driven and round column
- Spindle auto feed

#### Standard Accessories

- Allen wrench
- Wedge
- Tie rod

#### Optional Accessories

- Drill chuck
- Milling cutter holder
- Mill chuck
- Power feed attachment
- Auto-tapping electrical
- Paraller vise
- Working lamp
- Coolant system
- Machine stand and chip tray
- Clamping kits(58pcs)
- Rortary table
- 2-Axis DRO,3-Axis DRO
- Spindle box automatic lifting



SPECIFICATIONS	Units	DDM7032G/1	DDM7040FG/1	DDM7045FG/1
Max.drilling dia.	mm	32	40	45
Max.boring dia.	mm	50	60	70
Max.face milling dia.	mm	63	80	80
Max.end milling dia.	mm	20	32	32
Distance between spindle nose and table surface	mm	450	450	450
Min.distance from spindle axis to column	mm	260	260	260
Spindle travel	mm	130	130	130
Spindle taper	-	M.T.3 or R8	M.T.4 or R8	M.T.4 or R8
Spindle speed steps	-	6	6	6
Spindle speed	r.p.m	50Hz 80-1250	80-1250	80-1250
		60Hz 95-1500	95-1500	95-1500
Spindle feed steps	-	6	6	6
Spindle feed range	mm/r	0.06-0.30	0.06-0.30	0.06-0.30
Swivel angle of headstock (vertical)	-	±90	±90	±90
Table size	mm	800*240	800*240	800*240
Table travel	mm	500*175	500*175	500*175
Main motor Power	KW	0.75(1HP)	1.1	1.5
Machine weight	kg	370	373	375
Overall dimension	mm	770*880*1860	770*880*1860	770*880*1860
Loading amount	-	36pcs/20' container	36pcs/20' container	36pcs/20' container



## Milling Machine

**DVM5028**  
Vertical Milling Machine



**DVM(W)5032**  
Vertical Milling Machine



**DVM5036B / DVM5036B-1 / DVM5036K**  
Vertical Milling Machine



**Optional configuration**

- 3 axis DRO
- Universal dividing head
- Rotary table
- Clamping kits

SPECIFICATIONS	Units	DVM5028	DVM(W)5032	DVM5032K
Table size	mm	1200*280	1500*320	1500*320
Table travel	mm	650/320/350	800/300/320	800/300/400
T slot(number-width*pitch)	mm	3-14-50	3-16-70	3-16-70
Spindle taper	-	ISO40 7:24	ISO50 7:24	ISO50 7:24
Spindle speed range	rpm	40-1300(12steps)	40-1300(12steps)	40-1300(12steps)
Distance between spindle nose and table surface	mm	50-400	50-400	50-400
Distance from spindle axis to column surface	mm	320	320	320
Main motor power	kw	3	4	4
Machine Weight	kg	1500	2200	2400
Overall dimension	mm	1700*1700*1850	2000*1820*2100	2020*1800*2150

SPECIFICATIONS	Units	DVM5036B	DVM5036B-1	DVM5036K
Table size	mm	1500*360	1500*360	1500*360
Table travel	mm	800/320/450	1000/320/450	1000/320/450
T slot(number-width*pitch)	mm	3-18-80	3-18-80	3-18-80
Spindle taper	-	ISO50 7:24	ISO50 7:24	ISO50 7:24
Spindle speed range	rpm	60-1700(12steps)	60-1700(12steps)	60-1800(12steps)
Distance between spindle nose and table surface	mm	60-540	60-540	60-540
Distance from spindle axis to column surface	mm	360	360	360
Main motor power	kw	4	4	5.5
Machine Weight	kg	2700	2700	3300
Overall dimension	mm	2600*2200*2220	2600*2200*2220	2700*2300*2400



## Milling Machine

### DHM6032(B) Horizontal Milling Machine

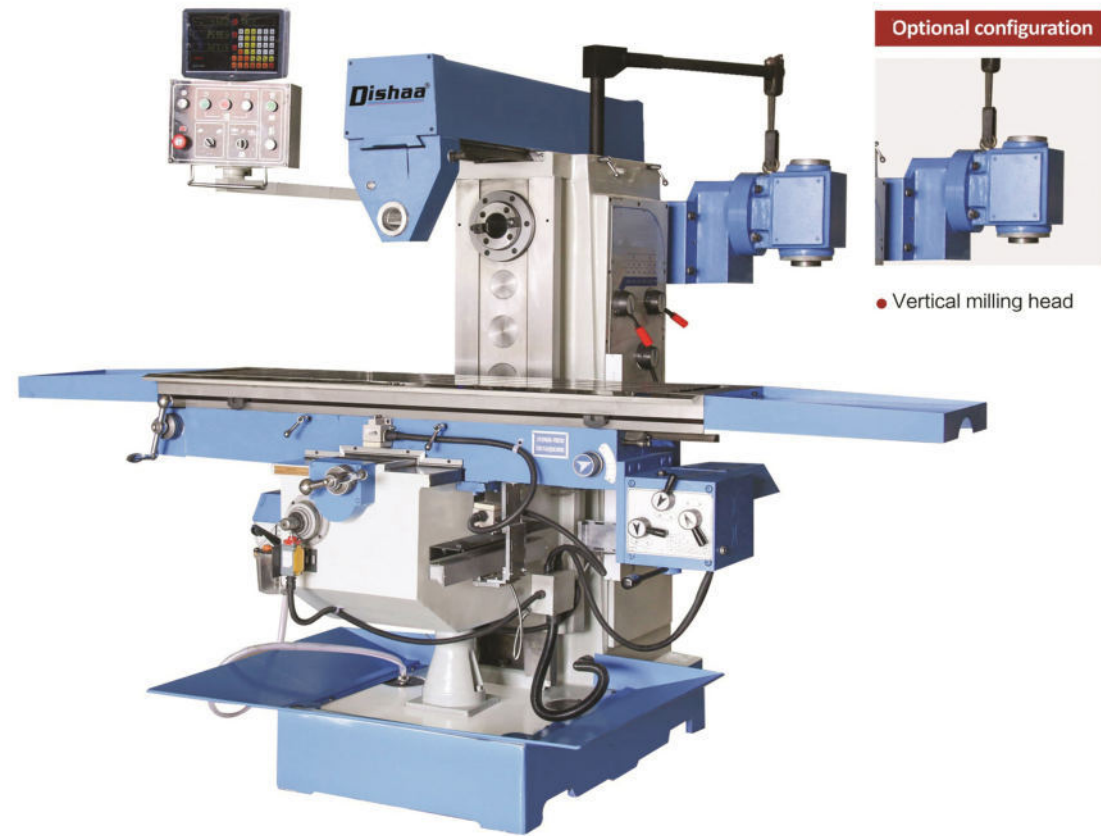

Optional configuration



• Vertical milling head

**Main features**

- X, Y motorized feed
- Z axis electric lifting

**Optional configuration**

- 3 axis DRO
- Rotary table
- Dividing head
- Clamping kit

SPECIFICATIONS	Units	DHM6128	DHM6032
Table size	mm	1200*280	1500*320
Table travel	mm	680/280/400	1000/300/400
T slot(number-width*pitch)	mm	3-14-50	3-16-70
Spindle taper	-	ISO40 7:24	ISO40 7:24
Spindle speed range(steps)	rpm	40-1300 (12)	40-1300 (12)
Distance between spindle axis and table surface	mm	0-400	0-400
Main motor power	kw	3	3
Machine weight	kg	1300	2050
Overall dimension	mm	1725*1450*1750	2070*1900*1850

### DHM6036 Horizontal Milling Machine



Optional configuration



• Vertical milling head

**Main features**

- X, Y motorized feed
- Z axis electric lifting

**Optional configuration**

- 3 axis DRO
- Rotary table
- Dividing head
- Clamping kit

SPECIFICATIONS	Units	DHM6036
Table size	mm	1500*360
Table travel	mm	1000/320/450
T slot(number-width*pitch)	mm	3-18*80
Spindle taper	-	ISO50 7:24 ISO40 7:24
Spindle speed range(steps)	rpm	60-1800 (12)
Distance between spindle axis and table surface	mm	0-450
Main motor power	kw	4
Machine Weight	kg	2400
Overall dimension	mm	2220*1790*1860



## Milling Machine

### DTM4H

Turret Milling Machine



**Optional configuration**

- 3 axis DRO
- automatic feed
- Electronic oil pump
- Rotary table
- Clamping kit
- pneumatic draw bar
- Dividing head
- cutter

SPECIFICATIONS	Units	DTM4H	DTM5H
Table size	mm	1270*254(10"*50")	1370*305(12"*54")
Table travel	mm	780/400/400	780/ 420 /420
T slot(number-width*pitch)	mm	3-16*50	3-16*65
Spindle taper	-	R8	R8
		opt.ISO40	opt.ISO40
Spindle speed range(steps)	rpm	50HZ:65-4500,60HZ:80-5440 (16) opt.(variable)65-4000	
Spindle travel	mm	127	127
Spindle feed range(steps)	mm	0.045,0.086,0.142(3)	
Distance between spindle nose and table surface	mm	90-510	90-510
Main motor power	kw	2.2	2.2
Head rotation (left - right )	°	±90°	±90°
Head rotation (front - rear)	°	±45°	±45°
Machine weight	kg	1400	1600
Overall dimension	mm	1550*1650*2250	1550*1650*2250

### DTM5H

Turret Milling Machine

**Optional configuration**



- Variable speed milling head



### DTM4HW

Turret Milling Machine



**Optional configuration**

- 3 axis DRO
- automatic feed
- Electronic oil pump
- Rotary table
- Clamping kit
- pneumatic draw bar
- Dividing head
- cutter

SPECIFICATIONS	Units	DTM4HW	DTM5HW
Table size	mm	1270*254	1370*305
Table travel	mm	780/420/400	810/420/400
T slot(number-width*pitch)	mm	3-16*65	3-16*65
Spindle taper	-	R8/ISO40	R8/ISO40
Horizontal spindle taper	-	ISO40	ISO40
Spindle speed range(steps)	rpm	50HZ:65-4500,60HZ:80-5440(16) opt.(variable)65-4000	
Horizontal spindle speed range(steps)	rpm	45-1350(12)	45-1350(12)
Spindle travel	mm	127	127
Spindle feed range(steps)t	mm	0.045,0.086,0.142(3 steps)	
Distance between spindle nose and table surface	mm	90-510	90-510
Distance between spindle axis and table surface	mm	0-400	0-400
Main motor power	kw	2.2(V)3(H)	2.2(V)3(H)
Head rotation (left - right )	°	±90°	±90°
Head rotation (front - rear)	°	±45°	±45°
Machine weight	kg	1750	1850
Overall dimension	mm	1550*1650*2250	1550*1650*2250



## Milling Machine

### DTM6325 / DTM6330 Turret Milling Machine



#### Optional configuration

- 3 axis DRO
- automatic feed
- Electronic oil pump
- Rotary table
- Clamping kit
- pneumatic draw bar
- Dividing head
- cutter

SPECIFICATIONS	Units	DTM6325	DTM6330
Table size	mm	1270*254(10"*50")	1370*305(12"*54")
Table travel	mm	780/400/400	810/400/400
T slot(number-width*pitch)	mm	3-16*50	3-16*65
Spindle taper	-	R8	R8/ISO40(opt.)
Horizontal spindle taper	-	-	ISO400
Spindle speed range(steps)	rpm	50HZ:65-4500 (16) 60HZ:80-5440 opt.variable 65-4000	50HZ:65-4500 (16) 60HZ:80-5440 opt.variable 65-4000
Horizontal spindle speed range(steps)	rpm	-	45-1350(12)
Spindle travel	mm	127	127
Spindle feed range(steps)	mm	0.045,0.086,0.142(3)	0.045,0.086,0.142(3)
Distance between spindle nose and table surface	mm	90-510	90-510
Distance between spindle axis and table surface	mm	-	120-520
Main motor power	kw	2.2	2.2(立V) 3(卧H)
Head rotation (left - right)	°	±90°	±90°
Head rotation (front - rear)	°	±45°	±45°
Machine weight	kg	1400	1850
Overall dimension	mm	1550*1650*2250	1550*1650*2250

### DTM6332 / DTM6336 Turret Milling Machine



#### Optional configuration

- 3 axis DRO
- automatic feed
- Electronic oil pump
- Rotary table
- Clamping kit
- pneumatic draw bar
- Dividing head
- cutter

SPECIFICATIONS	Units	DTM6328	DTM6332	DTM6336
Table size	mm	1200*280	1370*320	1500*360
Table travel	mm	600/240/360	800/300/400	1000/320/450
T slot(number-width*pitch)	mm	3-14*63	3-14*70	3-18*80
Spindle taper	-	ISO40 7:24	ISO40 7:24	ISO40 7:24
Horizontal spindle taper	-	ISO40 7:24	ISO40 7:24	ISO50 7:24
Spindle speed range(steps)	rpm	50HZ:65-4500 (16) 60HZ:80-5440 opt.(variable)65-4000	50HZ:65-4500 (16) 60HZ:80-5440 opt.(variable)65-4000	50HZ:65-4500 (16) 60HZ:80-5440 opt.(variable)65-4000
Horizontal spindle speed range(steps)	-	40-1300(12)	40-1300(12)	60-1800(12)
Spindle travel	mm	127	127	127
Spindle feed range(steps)	mm	0.045,0.086,0.142(3)	0.045,0.086,0.142(3)	0.045,0.086,0.142(3)
Distance between spindle nose and table surface	mm	140-500	140-540	140-590
Distance between spindle axis and table surface	mm	0-360	0-400	0-450
Main motor power	kw	2.2(V)3(H)	2.2(V)3(H)	3.7(V)4(H)
Head rotation (left - right)	°	±90°	±90°	±90°
Head rotation (front - rear)	°	±45°	±45°	±45°
Machine weight	kg	1400	2000	2400
Overall dimension	mm	1550*1650*2250	2200*1820*2350	2600*2200*2550



## Milling Machine

### DMX6226 / DMX6232 Rotary Head Milling Machine

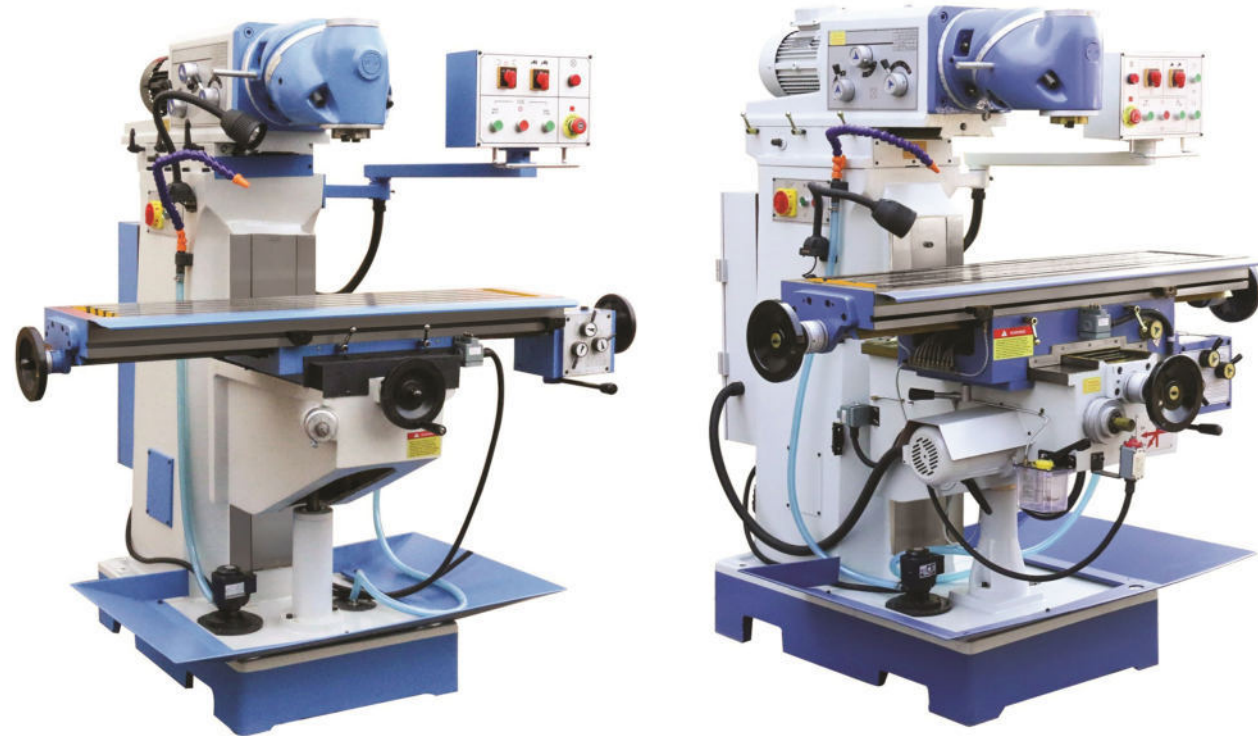

#### Optional configuration

- 3 axis DRO
- automatic feed
- Electronic oil pump
- Rotary table
- Clamping kit
- cutter
- Dividing head

SPECIFICATIONS	Units	DMX6226	DMX6232	DMX6236
Table size	mm	1200*260	1370*320	1500*360
Table travel	mm	600/280/400	800/320/400	1000/300/350
T slot(number-width*pitch)	mm	5-14*40	3-16*60	5-14*63
Spindle taper	-	ISO40	ISO40	ISO 50
Spindle speed range(steps)	rpm	48-1660(12)	48-1660(12)	45-1660/40-1300
Distance between spindle nose and table surface	mm	100-500	120-520	220-660
Distance between spindle axis and table surface	mm	-	-	0-440
Table feed range (steps)	mm /min	X:48-370(8) YZ:manual	XY:22-555(8) Z:electric	
Swivel angle of milling head	°	360	360	360
Main motor power	kw	3	3	4
Feed motor power	kw	0.75	1.1	
Machine weight	kg	1400	1700	2450
Overall dimension	mm	1660*1500*1750	1700*1560*1750	2020*1710*1994

### DUM6432 / DUM6436 Rotary Head Milling Machine



#### Optional configuration

- 3 axis DRO
- automatic feed
- Electronic oil pump
- Rotary table
- Clamping kit
- cutter
- Dividing head

SPECIFICATIONS	Units	DUM6432	DUM6438
Table size	mm	1500*320	1500*360
Table travel	mm	1000/320/400	1000/320/400
T slot(number-width*pitch)	mm	3-16*60	3-18*80
Spindle taper	-	ISO40(V) ISO40(H)	ISO40(V) ISO40(H)
Spindle speed range(steps)	rpm	48-1660(12)(V) 40-1300(12)(H)	48-1660(12)(V) 40-1300(12)(H)
Distance between spindle nose and table surface	mm	120-520	150-550
Distance between spindle axis and table surface	mm	0-400	0-400
Table feed range(steps)	mm /min	XY:22-555 (8) Z:electric	XY:22-555 (8) Z:electric
Swivel angle of milling head	°	360	360
Main motor power	kw	3(V)/3(H)	4(V)/4(H)
Feed motor power	kw	1.1	1.1
Machine weight	kg	2100	2580
Overall dimension	mm	2050*1750*2000	2550*2050*2050



## Milling Machine

### DXA7140

Bed Type Milling Machine



SPECIFICATIONS	Units	DXA7130	DXA7140
Table size	mm	1525*320	1400*400
Table travel	mm	1050*470	800*400
T slot(number-width*pitch)	mm	3-14*80	3-18*100
Spindle taper	-	ISO40	ISO50
Spindle travel	mm	127	105
Spindle speed range	rpm	70-3620	18-1800
Distance between spindle axis and table surface	mm	70-570	150-650
Distance from spindle axis to column surface	mm	450	520
Main motor power	HP	5	7.5
Machine weight	Kg	2300	3860
Overall dimension	mm	2565*2045*2290	2290*1840*2120

### DXA7150

Bed Type Milling Machine



SPECIFICATIONS	Units	DXA7150	DXA715	DXA716
Table size	mm	2000*400	2100*500	2500*575
Table travel	mm	1500*500	1500*670-670	1800(2000)*600*900
T slot(number-width*pitch)	mm	3-18*100	4-20*100	3-22*152
Spindle taper	-	ISO50	ISO50	ISO50
Spindle speed range	rpm	66-1440	35-1345	40-1200/12
Distance between spindle nose and table surface	mm	100-650	0-670	49
Distance from spindle axis to column surface	mm	600	610	110
Main motor power	HP	7.5	7.5	11
Machine weight	Kg	5000	7360	10000
Overall dimension	mm	3000*2285*2340	3300*2380*2750	4300*3200*3300



## Vertical Machining Center/ CNC Milling Machine

DVMC550 / DVMC640  
DVMC650 / DVMC840



### Standard configuration

- System:KND-1000/GSK980MDi
- 16 Armless Tool Magazine
- 3 axis Linear Rail

### Optional configuration



- 10000rpm spindle
- The 4th Axis
- 24 Arm
- SIEMENS,MITSUBISHI,FANUC,SYNTEC

SPECIFICATIONS	Units	DVMC550	DVMC640	DVMC650	DVMC840
Table size	mm	700*350	800*300	800*400	1000*400
X axis travel	mm	550	600	650	800
Y axis travel	mm	350	360	400	400
Z axis travel	mm	500	450	500	500
Max. worktable load	kg	300	300	400	450
T slot(number-width*pitch)	-	3-18*105	3-16*80	3-18*125	3-18*130
Max. spindle speed	rpm	8000(Optional:10000)			
Spindle taper	mm	BT40	BT40	BT40	BT40
Main motor power	kw	5.5	5.5	5.5	5.5
X/Y/Z rapid traverse speed	m/min	24/24/20 (Optional:48/48/36)			
Cutting feed speed	mm/min	1-10000	1-10000	1-10000	1-10000
Guide rail type	-	Linear rail	Linear rail	Linear rail	Linear rail
Distance from spindle axis to column surface	mm	400	410	469	520
Distance between spindle nose and table surface	mm	100-600	100-550	100-600	130-630
Positioning accuracy	mm	±0.0075	±0.0075	±0.0075	±0.0075
Repeat positioning accuracy	mm	±0.005	±0.005	±0.005	±0.005
Tool magazine	-	Armless 16( Optional: Arm24)			
Max. tool diameter	mm	φ90	φ90	φ90	φ90
Max.tool weight	kg	8	8	8	8
Machine weight	kg	3200	3000	4000	4200
Overall dimension	mm	2100*1950*2300	1900*1700*2100	2400*2000*2550	2500*2050*2550



## Vertical Machining Center/ CNC Milling Machine

DVMC1060 / DVMC1160  
DVMC1270 / DVMC1370



### Standard configuration

- |                     |                |                    |             |
|---------------------|----------------|--------------------|-------------|
| Name                | Brand          | Name               | Brand       |
| • Spindle Unit      | • ROYAL/POSA   | • Lubricating pump | • HERG      |
| • Pressure cylinder | • SP/AirTAC/SY | • Ball screw       | • HIWIN/PMI |
| • Bearing           | • NSK          | • Linear rail      | • HIWIN/PMI |
| • Coupling          | • R+W          | • Rail protection  | • KEYARROW  |
| • Tool magazine     | • OKADA        | • Electrical parts | • Schneider |

### Optional configuration



- The 5th Axis
- Oil coolant
- Oil-Water separator
- SIEMENS, MITSUBISHI, FANUC, SYNTEC

SPECIFICATIONS	Units	DVMC1060	DVMC1160	DVMC1270	DVMC1370
Table size	mm	1200*600	1200*600	1300*700	1400*700
X axis travel	mm	1000	1100	1200	1300
Y axis travel	mm	600	600	700	700
Z axis travel	mm	600	600	600	700
Max. worktable load	kg	800	1000	1200	1400
T slot(number-width*pitch)	-	5-18*120	5-18*125	5-18*125	5-22*140
Max. spindle speed	rpm	8000(Optional:10000)			
Spindle taper	mm	BT40	BT40	BT50	BT50
Main motor power	kw	11/15	11/15	11/15	15/18.5
X/Y/Z rapid traverse speed	m/min	24/24/20	24/24/20	24/24/18	24/24/18
Cutting feed speed	mm/min	1-8000	1-8000	1-6000	1-6000
Guide rail type	-	Linear rail	Linear rail	Linear rail	Linear rail
Distance from spindle axis to column surface	mm	650	650	780	780
Distance between spindle nose and table surface	mm	130-680	140-740	140-700	160-860
Positioning accuracy	mm	±0.0075	±0.0075	±0.0075	±0.0075
Repeat positioning accuracy	mm	±0.005	±0.005	±0.005	±0.005
Tool magazine	-	Arm 24	Arm 24	Arm 24	Arm 24
Max. tool diameter	mm	φ78 (Adjacent)/ φ120(Apart)		φ112 (Adjacent)/ φ200(Apart)	
Max.tool weight	kg	8	8	18	18
Machine weight	kg	6900	7000	9500	10000
Overall dimension	mm	3200*2600*2900	3400*2600*2900	3400*2900*3000	3870*2900*3000



## Shaper Machine



**DMS635A**  
Shaper Machine

SPECIFICATIONS	Units	DMS635A
Max. shaping length	mm	350
Table size	mm	350*300
Table horizontal travel (horizontal)	mm	400
Table vertical travel (vertical)	mm	270
Ram moving frequency per minute	times/min	32-125
Distance between ram lower end to table surface	mm	330
Tool head travel	mm	110
Tool head tilt angle	°	±60
Tool size	mm	20*30
		14
Main motor power	kw	1.5
Machine weight	kg	1250
Overall dimension	mm	1500*1100*1500



**DMS6085**  
Shaper Machine



**DMS6050/DMS6063  
DMS6066**  
Shaper Machine

SPECIFICATIONS	Units	DMS6050	DMS6063	DMS6066
Max. shaping length	mm	500	630	660
Table size	mm	440*360	630*400	660*400
Table horizontal travel (horizontal)	mm	525	630	630
Table vertical travel (vertical)	mm	270	360	360
Ram moving frequency per minute	times/min	14-80	14-80	14-80
Distance between ram lower end to table surface	mm	370	385	385
Tool head travel	mm	120	120	120
Tool head tilt angle	°	±60	±60	±60
Tool size	mm	20*30	20*30	20*30
	mm	18	18	18
Main motor power	kw	3	3	3
Machine weight	kg	1760	1870	1920
Overall dimension	mm	2000*1300*1600	2000*1300*1650	2000*1300*1650



**DMS60100**  
Shaper Machine

SPECIFICATIONS	Units	DMS6085	DMS60100	DMSH60100
Max. shaping length	mm	850	1000	1000
Table size	mm	800*450	1000*500	1000*500
Table horizontal travel (horizontal)	mm	710	800	800
Table vertical travel (vertical)	mm	360	380	380
Ram moving frequency per minute	times/min	17-100	15-83	3-44
Distance between ram lower end to table surface	mm	400	400	400
Tool head travel	mm	160	160	160
Tool head tilt angle	°	±60	±60	±60
Tool size	mm	30*45	30*45	30*45
	mm	22	22	22
Main motor power	kw	5.5	7.5	7.5
Machine weight	kg	3090	5150	5150
Overall dimension	mm	2450*1450*1800	3700*1600*1800	3700*1600*1800



## Circular Saw Machine DCS225 / DCS250 / DCS315 / DCS350



• Double vise

## Hacksaw Machine DHS7125 / DHS7132 / DHS7140 / DHS7150



Features

• Rotatable angle, manual clamping

SPECIFICATIONS	Units	DCS 225	DCS 250	DCS 315	DCS 350
Max. blade size	mm(")	225(8.9)	250 (9.8)	315 (12.4)	350 (13.8)
90°Circular	mm(")	60 (2.36)	60 (2.36)	100 (4)	120 (4.7)
90°Rectangular	mm(")	50*50(2*2)	75*45 (3*1.77)	140*90 (5.5*3.5)	140*100 (5.5*4)
45°Circular	mm(")	52 (2.05)	55(2.16)	90 (3.5)	105 (4.1)
45°Rectangular	mm(")	50*50 (2*2)	55*45 (2.16*1.77)	100*90 (4*3.5)	100*100 (4*4)
Blade speed	rpm	46	42	18,36	18,36
Max Vice opening	mm(")	70 (2.8)	100 (4)	145 (5.7)	145 (5.7)
Main motor power	kw	0.75/1.3	1.1/1.5	0.75/1.3	0.75/1.3
Drive	-	Gear	Gear	Gear	Gear
Machine weight	kg	63/75	143/171	185/207	190/212
Overall dimension	mm	64*39*72	89*58*78	980*620*900	980*620*950
			77*46*33	770x580x470	770x580x470

SPECIFICATIONS	Units	DHS7125	DHS7132	DHS7140	DHS7150
Cutting circular	mm	250	320	400	500
Cutting rectangular	mm	220*220	290*290	330*330	400*400
Cutting oblique	°	45	45	45	45
Blade speed	rpm	34,60,84	34,60,84	34,60,84	34,60,84
Blade size	mm	450*45*2.25	600*50*2.5	650*50*2.5	750*63*2.5
Main motor power	kw	2.22	3	3	3
Coolant motor power	kw	0.04	0.04	0.04	0.04
Saw blade rapid down	kw	0.25	0.25	0.25	0.25
Machine weight	kg	600/830	1100/1350	1200/1450	1450/1700
Overall dimension	mm	2000*950*1300	2440*1020*1600	2440*1020*1600	2440*1190*1760



## Sawing Machine



**DBS-115**  
Band saw machine



**DBS 712N**  
Band saw machine



**DBS 912B**  
sawing machine



**DBS 916V**



**DBS 280G**  
Band saw machine



**DBS 460G**  
Band saw machine



**DBS 1018B**



**DBS 1018R**

SPECIFICATIONS	Units	DBS-115	DBS 712N	DBS 280G	DBS 460G
90°Circular	mm(")	115(4.5)	178(7)	220(8.6)	330 (13)
90°Rectangular	mm(")	100*150mm(4*6)	178*305(7*12)	250 * 155(10*6.1)	460*250 (18*9.8)
60°Circular	mm(")	-	-	100(4)	205 (8)
60°Rectangular	mm(")	-	-	80*95 (3.1*3.7)	205*250 (8*9.8)
45°Circular	mm(")	100 (4)	127 (5)	160 (6)	305 (12)
45°Rectangular	mm(")	60*100(2.4*4)	120*125 (4.75*4.88)	160*110 (6.3 *4.3)	305*250 (12*9.8)
Blade speed	50HZ	20.29.50	27,41,59,78	40/80	40/80
	60HZ	24.35.61	22,34,49,64	48/96	48/96
Blade size	mm	13*0.6*1538	20*0.9*2362	27*0.9*2450	27*0.9*3960
Main motor power	kw	0.375	0.75	0.75/1.1	1.5/2.2
Drive	-	V-belt	V-belt	Gear	Gear
Machine weight	kg	68/72	145/178	254/287	750/830
Overall dimension	mm	970*460*460	1250*450*1150	1330*800*1050 670*400*620	2310*1070*1630

SPECIFICATIONS	Units	DBS 912B	DBS 916V	DBS 1018B	DBS 1018R
90°Circular	mm(")	229 (9)	229 (9)	254 (10)	254 (10)
90°Rectangular	mm(")	178*305 (7*12)	127*405 (5*16)	127 * 457(5*18)	160*406 (6.3*16)
45°Circular	mm(")	150 (6)	150 (6)	150 (6)	170 (6.7)
45°Rectangular	mm(")	127*150 (5*6)	150*190 (6*7.5)	150*190 (6*7.5)	160*190 (6.3*7.5)
Blade speed	50HZ	26,50,73,95	18-102	29,50,73,95	29,50,73,95
	60HZ	32,60,80,115	22-122	35,60,88,115	35,60,88,115
Blade size	mm	27*0.9*2655	27*0.9*3215	27*0.9*3280	27*0.9*3215
Main motor power	kw	1.1	1.5	1.5	1.5
Drive	-	V-belt	V-belt	V-belt	V-belt
Machine weight	kg	230/260	320/380	310/385	300/360
Overall dimension	mm	1540*590*1150	1800*770*1400	1830*830*1150	1890*840*1340



## DBSH4220 / DBSH4228 / DBSH4230

### DBSH4235 Band Saw Machine



#### Optional configuration



- Saw blade cover protection
- Protective cover power failure protection
- Fast down protection
- Saw blade hydraulic clamping

SPECIFICATIONS	Units	DBSH4220	DBSH4228	DBSH4230	DBSH4235
Cutting circular	mm	200	280	300	350
Cutting rectangular	mm	200*200	280*280	300*300	350*350
Blade speed	m/min	27,45,69	27,45,69	27,45,69	27,45,69
Blase size	mm	2800*27*0.9	3505*27*0.9	3505*27*0.9	4115*34*1.1
Main motor power	kw	1.5	2.2	3	3
Hydraulic motor power	kw	0.55	0.55	0.55	0.55
Coolant motor power	kw	0.04	0.04	0.04	0.04
Machine weight	kg	620	800	900	1000
Overall dimension	mm	1400*930*1270	1950*1100*1750	1950*1100*1750	2100*1160*1850

Specifications are subject to change without prior notice

## DBSH4240 / DBSH4250

### DBSH4260 Band Saw Machine



#### Optional configuration



- Saw blade variable speed
- Hydraulic chip conveyor
- Saw blade broken protection
- Electric feed rack

SPECIFICATIONS	Units	DBSH4240	DBSH4250	DBSH4260
Cutting circular	mm	400	500	600
Cutting rectangular	mm	400*400	500*500	600*600
Blade speed	m/min	27,45,69	27,45,69	27,45,69
Blase size	mm	5000*41*1.3	5800*41*1.3	6650*54*1.6
Main motor power	kw	4	5.5	5.5
Hydraulic motor power	kw	0.75	0.75	1.5
Coolant motor power	kw	0.09	0.09	0.125
Machine weight	kg	1500	1900	2300
Overall dimension	mm	2460*1270*2000	2960*1470*2200	3250*1600*2300

Specifications are subject to change without prior notice



## DBSH4265 / DBSH4270 DBSH4280 / DBSH42100

Band Saw Machine

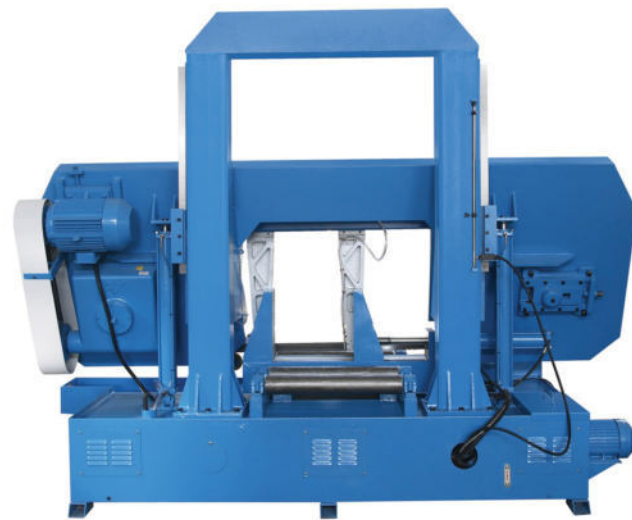

### Optional configuration

- Saw blade cover protection
- Protective cover power failure protection
- Fast down protection
- Saw blade hydraulic clamping
- Saw blade variable speed
- Hydraulic chip conveyor
- Saw blade broken protection
- Electric feed rack

SPECIFICATIONS	Units	DBSH4265	DBSH4270	DBSH4280	DBSH42100
Cutting circular	mm	650	700	800	1000
Cutting rectangular	mm	650*650	700*700	800*800	1000*1000
Blade speed	m/min	27,45,69	27,45,69	27,45,69	27,45,69
Blade size	mm	6900*67*1.6	7205*67*1.6	8820*67*1.6	9820*67*1.6
Main motor power	kw	5.5	7.5	7.5	11
Hydraulic motor power	kw	1.5	1.5	2.2	3.75
Coolant motor power	kw	0.125	0.125	0.125	0.125
Machine weight	kg	3100	5100	7100	8600
Overall dimension	mm	3500*1900*2400	3500*2000*2600	3560*2100*2700	4560*2170*3040

## DBHS4228 / DBHS4230 / DBHS4235 DBHS4240 / DBHS4250 DBHS4260

CNC Band Saw Machine

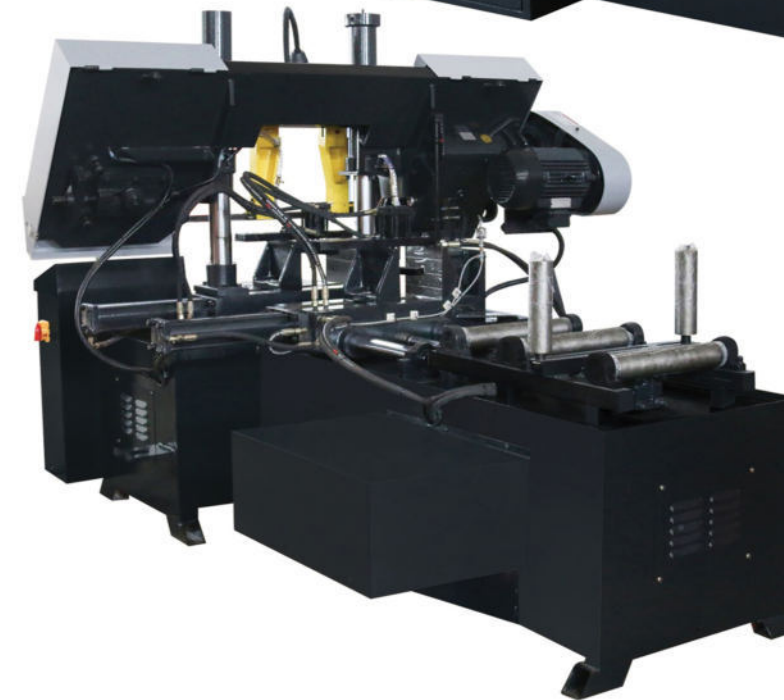

- Japan Omron CNC PLC control
- Fully automatic control, automatic feeding, automatic sawing, etc.
- Double hydraulic vise
- Grating ruler test
- Angle sawing

SPECIFICATIONS	Units	DBHS4228	DBHS4230	DBHS4235	DBHS4240	DBHS4250	DBHS4260
Cutting circular	mm	280	300	350	400	500	600
Cutting rectangular	mm	280*280	300*300	350*350	400*400	500*500	600*600
Blade speed	m/min	27,45,69	27,45,69	27,45,69	27,45,69	27,45,69	27,45,69
Blade size	mm	3505*27*0.9	3505*27*0.9	4115*34*1.1	5000*41*1.3	5800*41*1.3	6650*54*1.6
Main motor power	kw	2.2	3	4	5.5	5.5	5.5
Hydraulic motor power	kw	0.75	0.75	0.75	0.75	1.5	1.5
Coolant motor power	kw	0.09	0.09	0.09	0.09	0.09	0.125
Machine weight	kg	1400	1500	1700	2100	2500	3100
Overall dimension	mm	2000*2430*1650	2000*2450*1650	2250*2450*1600	2460*2320*2000	2960*2320*2200	3280*2320*2400



## DBHZ4228 / DBHZ4230 / DBHZ4235

## DBHZ4240 / DBHZ4250

Rotary Band Saw Machine

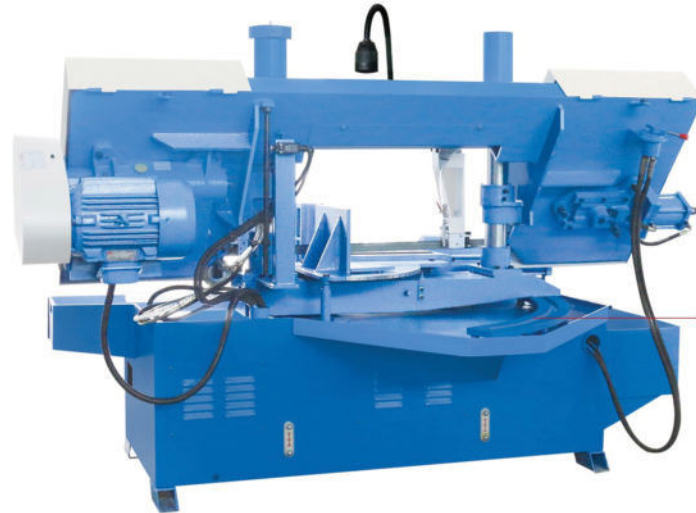

### Optional configuration

- Saw blade cover protection
- Protective cover power failure protection
- Fast down protection
- Saw blade hydraulic clamping
- Saw blade variable speed
- Hydraulic chip conveyor
- Saw blade broken protection
- Electric feed rack

SPECIFICATIONS	Units	DBHZ4228	DBHZ4230	DBHZ4235	DBHZ4240	DBHZ4250
90°Circular	mm	280	300	350	400	500
90°Rectangular	mm	300*280	320*300	380*350	600*400	700*500
45°Circular	mm	190	200	200	300	400
45°Rectangular	mm	210*190	220*200	240*220	400*300	500*400
Blade speed	m/min	27,45,69	27,45,69	27,45,69	27,45,69	27,45,69
Blase size	mm	3505*27*0.9	3850*27*0.9	4525*34*1.1	5050*41*1.3	5880*41*1.3
Main motor power	kw	2.2	3	4	5.5	5.5
Hydraulic motor power	kw	0.55	0.55	0.55	1.5	1.5
Coolant motor power	kw	0.04	0.04	0.04	0.125	0.125
Machine weight	kg	850	950	1050	1600	1900
Overall dimension	mm	2100*1300*1550	2100*1300*1550	2300*1350*1650	2460*1950*2000	2960*2150*2200

## DBSZ4228-CNC / DBSZ4230-CNC / DBSZ4235-CNC

## DBSZ4240-CNC / DBSZ4250-CNC

CNC Rotary Band Saw Machine



- Japan Omron CNC PLC control
- Fully automatic control, automatic feeding, automatic sawing, etc.
- Double hydraulic vise
- Grating ruler test
- Double column structure, precision sawing cutting
- Angle sawing

SPECIFICATIONS	Units	DBSZ4228-CNC	DBSZ4230-CNC	DBSZ4235-CNC	DBSZ4240-CNC	DBSZ4250-CNC
90°Circular	mm	280	300	350	400	500
90°Rectangular	mm	300*280	320*300	380*350	600*400	700*500
45°Circular	mm	190	200	200	300	400
45°Rectangular	mm	210*190	220*200	240*220	400*300	500*400
Blade speed	m/min	27,45,69	27,45,69	27,45,69	27,45,69	27,45,69
Blase size	mm	3505*27*0.9	3850*27*0.9	4525*34*1.1	5050*41*1.3	5880*41*1.3
Main motor power	kw	2.2	3	4	5.5	5.5
Hydraulic motor power	kw	0.55	0.55	0.55	1.5	1.5
Coolant motor power	kw	0.04	0.04	0.04	0.125	0.125
Machine weight	kg	1500	1600	1800	2200	2600
Overall dimension	mm	2100*1300*1550	2100*1300*1550	2300*1350*1650	2460*1950*2000	2960*2150*2200



### 3-IN-1 Combination of Shear, Brake & Roll Machine



**D3-IN-1/305**

- ▶ Ideal combination machine for sheet metal machining to a length of 305mm and a thickness of 1.0 mm cutting stop
- ▶ Roll bending starting with diameter of 39mm
- ▶ Folding with a max. angle of 90°
- ▶ Adjustable rear stop



**D3-IN-1/1067x1.5**

Model	D3-IN-1/1067 x1.5	D3-IN-1/1320 x1.5
Bed width(mm)	1037	1320
Max. shearing thickness(mm)	1.5	1.5
Max. bending thickness(mm)	1.5	1.5
Max. bending angle	90°	90°
Max. rolling thickness(mm)	1.5	1.5
Min. rolling dia.(mm)	62	76
Packing size(cm)	150×59×93	179×59×93
N.W./G.W.(kg)	390/440	470/530



**D3-IN-1/1016**

- ▶ Removable male dies with female dies
- ▶ Back gauge standard equipment
- ▶ With two position handles
- ▶ Shearing mild steel or equipment
- ▶ Press brake-bends box and pan works
- ▶ Sectional fingers allow box and pan works
- ▶ Slip roll provided with forming grooves

Model	D3-IN-1/200	D3-IN-1/305	D3-IN-1/610	D3-IN-1/760	D3-IN-1/1016	D3-IN-1/1067	D3-IN-1/1320
Bed width(mm)	200	305	610	760	1016	1067	1320
Max. shearing thickness(mm)	1.0	1.0	1.0	1.0	1.0	1.0	1.0
Max. bending thickness(mm)	1.0	1.0	1.0	1.0	1.0	1.0	1.0
Max. bending angle	90°	90°	90°	90°	90°	90°	90°
Max. rolling thickness(mm)	1.0	1.0	1.0	1.0	1.0	1.0	1.0
Min. rolling dia.(mm)	29	39	39	39	43	43	43
Packing size(cm)	54×24×28	49×33×42	84×41×86	100×41×66	137×45×72	139×54×78	168×54×78
N.W./G.W.(kg)	19/20	43/45	112/123	136/153	195/215	276/297	349/377

### E3-IN-1 Electric Combination of Shear, Brake & Roll Machine



**DE3-IN-1/1320**

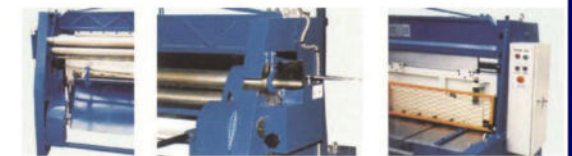

Model	DE3-IN-1/1320
Max. shearing thickness(mm)	3.0
Max. shearing width(mm)	1320
Shearing angle	2
Number of stroke(per min)	30
Back-gauge range(mm)	450
Height of worktable(mm)	760
Max. bending thickness(mm)	2.0
Max. bending width(mm)	1320
Max. rolling thickness(mm)	3.0
Max. rolling width(mm)	1500
Min. rolling dia.(mm)	90
Mortor power	3.0
Packing size(cm)	254×145×197
N.W./G.W.(kg)	2300/2800

- ▶ Combination of shear, brake & roll
- ▶ For shearing, it can achieve single stroke and continuous stroke processing function
- ▶ For bending, there are two functions: Jogging and continuous stroke
- ▶ This machine is the ideal equipment for sheet-metal working



## Electric Shearing Machine



**D11-3x2050**

- ▶ Manual back gauge with mm-counter
- ▶ Cutting line lighting
- ▶ Mobile 24V foot switch
- ▶ Automatic rubber-coated sheet hold
- ▶ Bench angle-stop



**D11-2x2550**

- ▶ PLC-control
- ▶ Cutting line lighting
- ▶ Mobile 24V foot switch
- ▶ Two sides shear blades
- ▶ Graphical control system with Finger touch screen
- ▶ Rear guarding with interlock
- ▶ Sheet hold down devices with rolling balls
- ▶ Sheet catcher, pneumatic type
- ▶ Motorized back-gauge with manual fine adjustment

Model	D11-3x1250	D11-3x2050	D11-4x1300	D11-2x2550
Max shearing thickness(mm)	3.0	3.0	4.0	2.0
Max shearing width(mm)	1250	2050	1300	2550
Shearing angle	2°	2°	2.4°	1.6°
No. of stroke (per minute)	30	30	30	30
Motor power(kW)	3	4	4	4
Back gauge(mm)	630	630	630	630
Dimension(cm)	184×103×135	266×116×147	191×116×145	320×116×148
N.W./G.W.	980/1140	1520/1650	1320/1520	1900/2150

## Manual Shearing Machine

- ▶ Cast iron frame
- ▶ With both front & back gauge
- ▶ Used for mild steel, aluminium copper, brass zinc plastic and leads
- ▶ High carbon and chrome steel blade



**D01-1.5x1320**



- ▶ Steel plate structure
- ▶ with Lower pedal
- ▶ Used for mild steel, aluminium copper, brass zinc plastic and leads
- ▶ High carbon and chrome steel blade

**D01-1.5x1320A**

- ▶ Used for mild steel, aluminium copper, brass zinc plastic and leads
- ▶ High carbon and chrome steel blade
- ▶ Hand control

**D01-1.5x1500**



Model	D01-1.0x1000	D01-1.5x1320	D01-2x1000	D01-1.5x1320A	D01-1.5x1500	D01-1.25x2000
Width (mm)	1000	1320	1000	1320	1500	2000
Max. shearing thickness (mm)	1.0	1.5	2.0	1.5	1.5	1.25
Back gauge range (mm)	0-840	0-840	0-840	0-840	0-300	0-300
Packing size (cm)	140×76×115	168×76×115	140×76×115	168×76×115	208×76×120	258×76×120
N.W./G.W.(kg)	365/410	491/545	430/490	460/520	445/515	511/600



## Manual Folding Machine

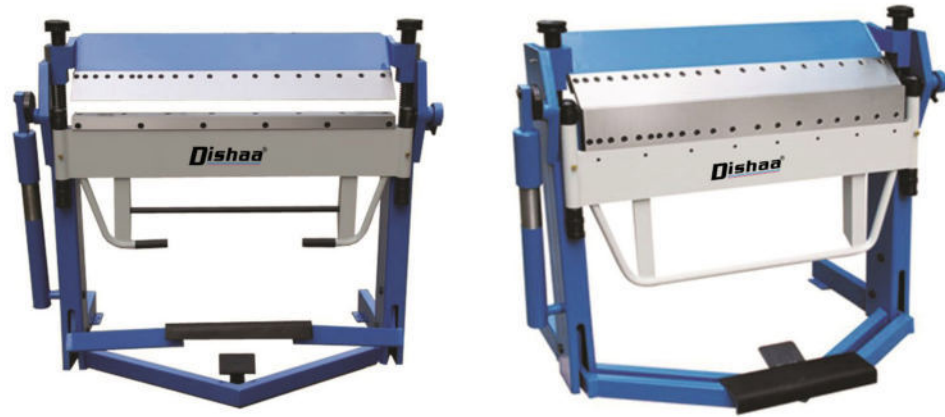

### Features

- They have the function of air spring which can be installed inside the arm (optional)
- Our precision folding machine is used for bending the sheet metal parts. The upper blade can be dismantled for use. It can choose a combination of upper blades according to the abnormality degree and length of the workpiece.

Model	DPB1020/2.5	DPB1270/2	DPB1520/1.5	DPB2020/1.2	DPB2520/1.0
Max. working length(mm)	1020	1270	1520	2020	2520
Max. sheet thickness(mm)	2.5	2.0	1.5	1.2	1.0
Max. clamping bar lift(mm)	47	47	47	47	47
Folding angle	0-135°	0-135°	0-135°	0-135°	0-135°
Packing size (cm)	146X62X127	170X71X127	196X71X130	247X94X132	297X94X132
N.W./G.W(kg)	285/320	320/360	385/456	490/640	590/770

### Features

- A fully developed quick release system for the clamp beam segment ensures fast interchangeability
- The folding beams are fitted with a counter-balance and angle stop to provide a perfect and effective operation within the full capacity of the machine
- The optional back-gauge can be easily mounted when using the pre-drilled fixing point

Model	DPB1020/2A	DPB1270/2A	DPB1520/1.5A	DPB1020/3SH	DPB1270/3SH
Max. working length (mm)	1020	1270	1520	1020	1270
Max. sheet thickness (mm)	2.0	2.0	1.5	2.0	1.5
Max. clamping bar lift (mm)	47	47	47	45	45
Folding angle	135°	135°	135°	150°	150°
Packing size(cm)	146x62x127	170x71x127	196x71x130	142x59x142	167x66x142
N.W./G.W.(kg)	320/350	350/385	395/466	430/470	465/510

## Pan & Box Brake Machine



### Features

- With segment bending blade for the bending of box section.
- Various widths segment shiftable setup.
- With balanced hammer , it can easy to operate and easy for folding

Model	Capacity (mm)			Packing size(cm)	N.W./G.W.(kg)
	Length	Thickness	Angle		
DW2.5X1220	1220mm(48")	2.5mm(12Ga)	0-135°	171x75x94	513 / 575
DW2.0X2040A	2040mm(80")	2.0mm(14Ga)	0-135°	255x76x100	850/1000
DW2.5X2040A	2040mm(80")	2.5mm(12Ga)	0-135°	255x76x100	1145/1295
DW2.0X2540A	2540mm(100")	2.0mm(14Ga)	0-135°	300x76x100	1190/1360
DW2.5X2540A	2540mm(100")	2.5mm(12Ga)	0-135°	300x76x100	1310/1480
DW2.0X3050A	3050mm(120")	2.0mm(14Ga)	0-135°	350x76x110	1490/1690
DW1.2X3700A	3700mm(146")	1.2mm(20Ga)	0-135°	425x85x120	2450/2670
DW0.8X4000A	4000mm(157")	0.8mm(22Ga)	0-135°	470x90x120	2700/2950



## Slip Roll Machine



DMER-1300x1.5



DMER-1300x4.5

- ▶ Asymmetrical roll bending machine with 3 high strength steel rolls
- ▶ Fixed top roller, adjustable lower and rear rollers
- ▶ Standard series wire core groove
- ▶ Top roll swing out across cam lock
- ▶ Supplied with conical bending feature

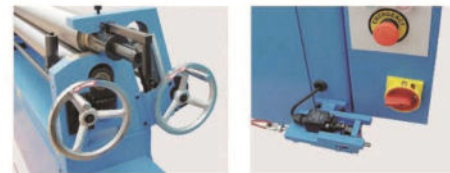

Model	Max.rolling thickness(mm)	Max.rolling width(mm)	Dia.of roller(mm)	Motor power(kW)	Dimension(cm)	N.W./G.W.(kg)
DMER-1300x1.5	1.5	1300	75	0.75	180x65x110	280/340
DMER-1300x2.5	2.5	1300	90	1.5	200x72x120	540/600
DMER-1300x4.5	4.5	1300	120	2.2	200x76x127	750/830
DMER-1550x3.5	3.5	1550	120	2.2	222x76x127	790/890
DMER-2020x3.0	3.0	2020	127	4.0	270x87x130	1100/1200

## Manual Rolling Machine

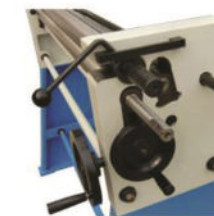

Model	Max.Thickness (mm)	Max. width (mm)	Dia.of roll (mm)	Packing size (cm)	N.W./G.W. (kg)
DMMR-2x1000	2	1000	60	155x62x118	200/240
DMMR-2x1250	2	1250	60	180x62x118	223/262
DMMR-1.5x1300	1.5	1300	75	175x45x60	235/270



## Bead Bending Machine

- ▶ Heavy and solid cast iron construction
- ▶ Special steel adjustable bottom spindle
- ▶ Self-braking motor with subframe(E-type)
- ▶ Easy to operate with foot pedal control(E-type)
- ▶ 4 sets standard rollers



DBB 12

Model	DBB 12	DEBB12
Thickness max	1.2mm/18Ga	1.2mm/18Ga
Cylinder length	140mm/5-1/2"	140mm/5-1/2"
Throat depth	200mm/8"	200mm/8"
Cylinder speed		32rpm
Motor power		0.75kW/1HP
Net weight	48kg/106lb	120kg/265lb
Packing(cm)	67x32x60	110x48x148

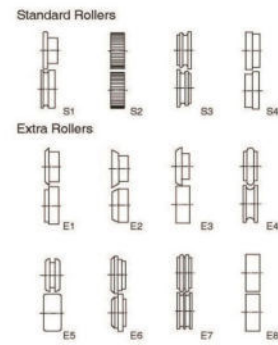

- ▶ Steel welded construction frame
- ▶ Adjustable idle roller
- ▶ Steel shaft with bronze bushings
- ▶ Reduction motor with brake system
- ▶ Movement of rollers with foot pedal
- ▶ Complete with stand
- ▶ 4 sets standard rollers



DEBB 25  
DEBB 40

Model	DEBB 25	DEBB 40
Thickness max	2.5mm 12Ga	4mm 8Ga
Cylinder length	120mm 4-3/4"	165mm 6-1/2"
Throat depth	280mm 11"	300mm 12"
Cylinder speed	20rpm	15.3rpm
Motor power	1.5kW/2HP	2.2kW/3HP
Net weight	235kg/518lb	341kg/752lb
Packing(cm)	147x58x135	165x58x140

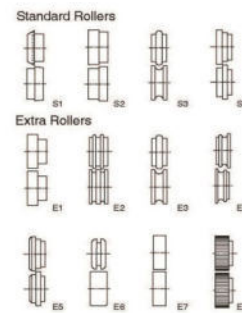

## Rotary Machine

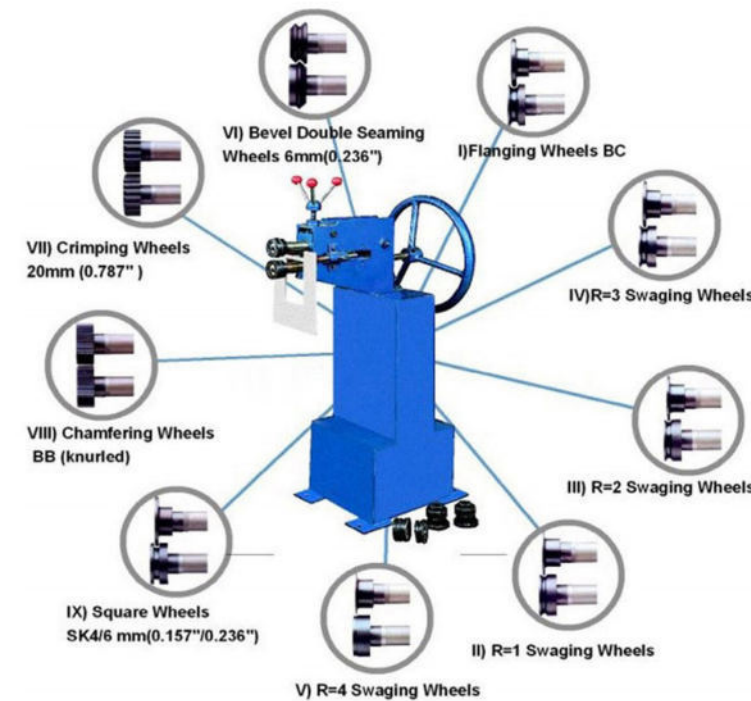

### Technical Parameters

Model	Shape	Capacity (mm)	Motor (kw)	Weight (kg)	Dimension size (L.W.H)(mm)
DLX-18		1.8	2.2	145	850x450x1180
DLX-15		1.5	0.75	85	870X400X1000
DLH-10		1.0	—	50	470X615X1030



## Bench Grinding Machine



### Technical Parameters

Model	DBG3020	DBG3025	DBGQ3025	DBG3030	DBG3035	DBG3040
Wheelsize(mm)	200x25x32	250x25x32	250x25x32	300x40x75	350x40x75	400x40x127
Power(Kw)	0.5	0.75	1.1	1.5	1.75	2.2
Voltage(V)	380					
Phase	3 Phases					
Speed(r/min)	2850	2850	2850	1440	1440	1440
Dimensions(mm)	400x420x900	500x405x965	500x405x965	680x450x1030	690x450x1050	710x500x1075
Weight(Kg)	37	46	48	97.5	105	113
foot size(mm)	370x350xΦ 16	350x350xΦ 16	350x350xΦ 16	388x428xΦ 16	388x428xΦ 16	388x428xΦ 16

Model	DBG3320	DBG3325	DBG3330	DBG3335	DBG3340
Wheelsize(mm)	200x25x32	250x25x32	300x40x75	350x40x75	400x40x127
Power(Kw)	main motor 0.75 dust removal motor 0.75	main motor 1.5 dust removal motor 0.75	main motor 2 dust removal motor 1.1	main motor 2.5 dust removal motor 1.1	main motor 2.7 dust removal motor 1.1
Voltage(V)	380				
Phase	3 Phases				
Speed(r/min)	2800	2800	1440	1440	1440
Dimensions(mm)	500x840x1040	540x750x1000	500x840x1100	500x840x1130	500x840x1130
Weight(Kg)	81.5	140	226	231	270
foot size(mm)	350x750xΦ 12	322x648xΦ 12	428x820xΦ 12	350x750xΦ 12	350x750xΦ 12

## Lock Former Machine



Model	Motor (kw)	Capacity (mm)	Shape	Weight (kg)	Dimension size (L.W.H)
DLF-10	1.5	0.3-1.0		175	920X580X890
DLF-10R	1.5	0.3-1.0		185	920X580X1020
DLF-10C	1.5	0.3-1.0		185	920X580X1020
DLF-10E	2.2	0.3-1.0		220	1200X600X950
DLF-10B	1.5	0.3-1.0		175	920X580X880
DLF-10BR	1.5	0.3-1.0		185	920X580X1020
DLF-12	1.5	0.5-1.2		215	1050X580X880
DLF-12R	1.5	0.5-1.2		220	1050X580X1050
DLF-12B	1.5	0.5-1.2		210	1050X580X880
DLF-12BR	1.5	0.5-1.2		225	1050X580X1060
DLF-12C	1.5	0.5-1.2		210	1050X580X880
DLF-12D	1.5	0.5-1.2		215	1050X580X880
DLF-12DR	1.5	0.5-1.2		230	1050X580X1050
DLF-12M	2.2	0.5-1.2		360	1520X650X1010
DLF-12MR	2.2	0.5-1.2		370	1152X650X1050
DLF-15	2.2	0.7-1.5		280	1140X660X920
DLF-15R	2.2	0.7-1.5		305	1150X660X1080
DLF-15B	2.2	0.7-1.5		285	1150X660X920
DLF-15BR	2.2	0.7-1.5		305	1150X660X1080
DLF-15C	2.2	0.7-1.5		290	1150X660X1080
DLF-15D	2.2	0.7-1.5		290	1420X660X920
DLF-15DR	2.2	0.7-1.5		310	1650X660X1080
DLF-15M	2.2	0.7-1.5		360	1420X680X1160
DLF-20	3.0	0.7-2.0		435	1650X650X1050



## NC Pipe Bending Machine



DMP 168/219/325/400 NC



### Mechanical Characteristics

The microcomputer control is adopted with strong functions, high extensibility, English subtitles and dialogue-based operation, easy to learn and understand. Set speed by segmentation with high precision of elbow pipes. The sixteenth level elbow pipe data setting and storage, and remarkably smooth assembly of work pieces of many angles. The functions of reloading with auxiliary shoving and slowly returning the core can be achieved. The thin-wall pipes can be bent and manufactured. Extensively used in large ship building and repair, boiler, petroleum pipeline and auto spare parts.

	DMP168NC	DMP219NC	DMP325NC	DMP400NC
Min bending R for carbon pipe is:1.5D	ø168x14.0t	ø219x18.0t	ø325x20.0t	ø400x22.0t
Min bending R for S.S pipe is:1.5D	ø135x10.0t	ø168x10.0t	ø275x12.0t	ø325x14.0t
Availability length of bending pipe	3600mm	4000mm	4500mm	4500mm
Max R for bending	550mm	700mm	1000mm	1150mm
Max angle for bending	185°	185°	185°	185°
Bending process for every pipe	16	16	16	16
Oil pressure	14mpa	14mpa	14mpa	14mpa
Electrical motor power	30kw	45kw	55kw	55/75kw
Weight	12000kg	18000kg	21000kg	27000kg
Size (LxWxH) (cm)	630x250x130	690x225x175	720x230x180	730x230x185



DMPNCBL

### Mechanical Characteristics

Adopt PLC+ touch screen control imported from Taiwan and Chinese-English subtitles with easy operation. Adopt servo motor imported from Japan + Taiwan reduction gears, accurately segment precision, set speed of elbow pipe with its high precision. The angle of elbow pipe can be set for many times in the sixteenth level elbow pipe data setting and storage. The thin-wall pipes can be bent and manufactured. Adopt manual feeding materials, set the length of feeding materials with limited block, and automatically adjust the pipe angle, with accurate precision and extremely high cost performance.

	DMP38NCBL	DMP50NCBL	DMP63NCBL	DMP75NCBL	DMP89NCBL	DMP115NCBL	DMP130NCBL	DMP168NCBL
Min bending R for carbon pipe is:1.5D	ø38.1x2.0t	ø50.8x2.0t	ø63.5x2.1t	ø76.2x2.5t	ø88.9x3.0t	ø115x6.0t	ø130x8.0t	ø168x10t
Min bending R for S.S pipe is:1.5D	ø31.7x1.5t	ø34x2.2t	ø38x2.0t	ø51x2.0t	ø57x2t	ø89x2.0t	ø102x3.5t	ø133x6t
Manual feed distance	2100mm	2200mm	2200mm	2200mm	2500mm	2700mm	2800mm	4500mm
*Max R for bending	175mm	200mm	200mm	300mm	300mm	500mm	500mm	550mm
*Max angle for bending	185°	185°	185°	185°	185°	185°	185°	185°
Bending process for every pipe	16	16	16	16	16	16	16	8
Oil pressure	12mpa	14mpa	14mpa	14mpa	14mpa	14mpa	14mpa	14mpa
Electrical motor power	4kw	5.5kw	5.5kw	7.5kw	11kw	22kw	22kw	30kw
Weight	1150kg	1500kg	1600kg	2700kg	2850kg	8000kg	11000kg	12500kg
Size (LxWxH) (cm)	380x100x130	390x80x140	410x90x130	450x90x120	480x118x130	530x160x140	540x180x140	630x250x130

\*Can be customized





## NC Pipe Bending Machine

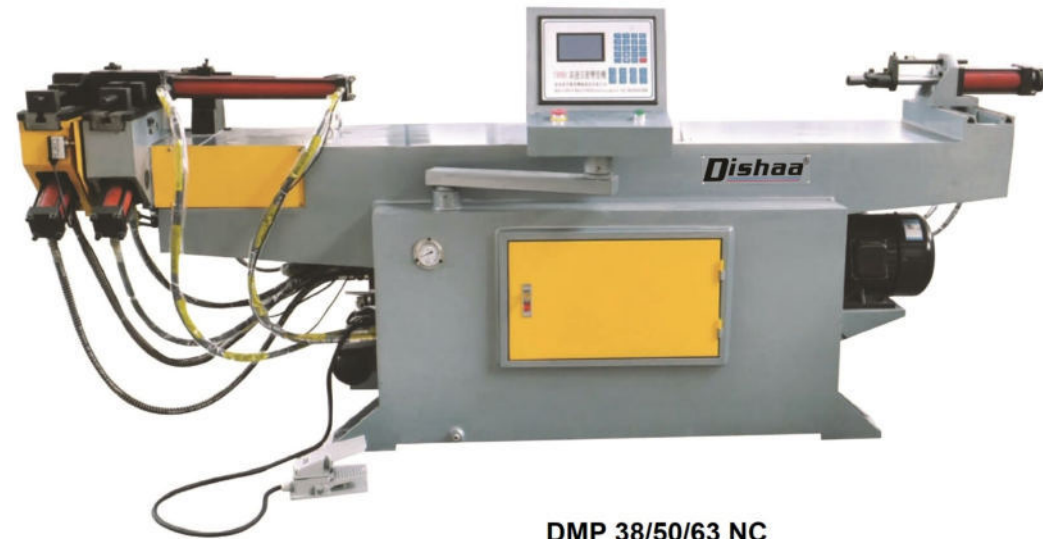

**DMP 38/50/63 NC**



**DMP 75/89/115/130 NC**

NC PIPE BENDING

NC PIPE BENDING

	DMP25NC	DMP38NC	DMP50NC	DMP63NC
Min bending R for carbon pipe is:1.5D	ø25.1x1.5t	ø38.1x2.0t	ø50.8x2.0t	ø63.5x2.5t
Min bending R for S.S pipe is:1.5D	ø22.1x1.5t	ø31.75x1.5t	ø35x2.2t	ø38x2.0t
Availability length of bending pipe	1450mm	1800mm	2200mm	3100mm
Max R for bending	90mm	175mm	200mm	220mm
Max angle for bending	185°	185°	185°	185°
Bending process for every pipe	16	16	16	16
Oil pressure	12mpa	14mpa	14mpa	14mpa
Electrical motor power	3kw	4kw	5.5kw	5.5kw
Weight	850kg	1200kg	1350kg	1500kg
Size	230x70x110	260x73x123	310x75x120	320x80x130



	DMP75NC	DMP89NC	DMP115NC	DMP130NC
Min bending R for carbon pipe is:1.5D	ø76.2x3.0t	ø88.9x3.0t	ø115x6.0t	ø130x8.0t
Min bending R for S.S pipe is:1.5D	ø51x2t	ø57x2t	ø88.9x2.0t	ø102x3.0t
Availability length of bending pipe	3100mm	3500mm	3600mm	3700mm
Max R for bending	280mm	300mm	500mm	500mm
Max angle for bending	185°	185°	185°	185°
Bending process for every pipe	16	16	16	16
Oil pressure	14mpa	14mpa	14mpa	14mpa
Electrical motor power	7.5kw	11kw	22kw	22kw
Weight	2500kg	3050kg	7000kg	8500kg
Size (LxWxH) ( cm )	450x110x150	480x120x130	530x160x140	540x180x140





## CNC Pipe Bending Machine

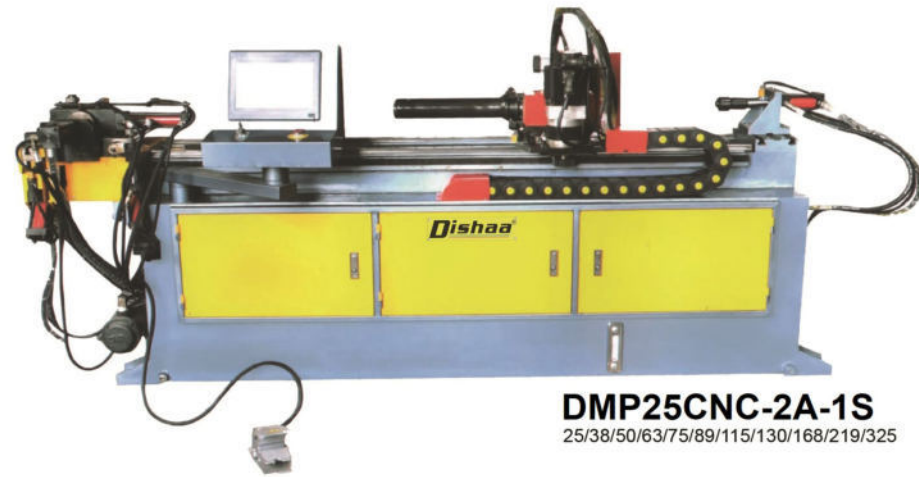

**DMP25CNC-2A-1S**  
25/38/50/63/75/89/115/130/168/219/325

### Properties

Automatic identification of dynamic characteristics of machine tool/work piece-rapid and good processing;  
Return the core and boost with trolley---improve the appearance of corner piece.  
The Chinese operation prompts +15 inch true color display + touch screen---simple and clear operation.  
The graphical programming system: the processing procedure can be obtained upon the vertical tube painting system/modification on the screen --- simple, convenient, rapid and accurate programming.  
Resilience measurement- the property of batches of pipes can be compared and measured.  
Single-step debugging function --- the deformation process of pipes is observed closely during mould trial-manufacture.  
Automatic mould drawing --- help significantly develop new products.  
Comprehensive monitoring: Hydraulic/electrical/drive system, motor phase loss/reversal, voltage, temperature, oil pressure, automatic fault diagnosis, passwords, key, records of working hours/number, for production management.

	DMP25 CNC-2A-1S	DMP38 CNC-2A-1S	DMP50 CNC-2A-1S	DMP63 CNC-2A-1S	DMP75 CNC-2A-1S	DMP89 CNC-2A-1S
Min bending R for carbon pipe is 1.5D	ø25.1x1.6t	ø38.1x2.0t	ø50.8x2.0t	ø63.5x2.0t	ø76.2x2.0t	ø88.9x2.0t
Max feed distance	1300mm	2100mm	2400mm	2500mm	2800mm	3000mm
Feeding method	Servo motor					
Max R for bending	175mm	175mm	250mm	250mm	300mm	300mm
*Max angle for bending	185°	185°	185°	185°	185°	185°
Bending process for every pipe	16	16	16	16	16	16
Max bending group	200	200	200	200	200	200
working rate	Bending Rate	Max.45	Max.45	Max.40	Max.35	Max.30
	Rotary Rate	Max.270	Max.270	Max.270	Max.270	Max.180
	Feeding Rate	Max.700	Max.700	Max.700	Max.700	Max.600
	Bending Angle	± 0.15°	± 0.15°	± 0.15°	± 0.15°	± 0.15°
working Accuracy	Rotary Angle	± 0.1°	± 0.1°	± 0.1°	± 0.1°	± 0.1°
	Feeding Length	± 0.1mm	± 0.1mm	± 0.1mm	± 0.1mm	± 0.1mm
	Data Input Method	( Y.B.C )	( Y.B.C )	( Y.B.C )	( Y.B.C )	( Y.B.C )
Rotary Servo motor Power	400w	850w	850w	850w	1300w	1300w
Feeding Servo motor Power	750w	1300w	1300kw	1300kw	2000kw	2000kw
Electric Motor Powre	4Kw	4Kw	5.5Kw	5.5Kw	7.5Kw	11Kw
Weight	1000kg	2100kg	2500kg	2800kg	3600kg	3800kg
Size (LxWxH) ( cm )	250x60x120	380x100x130	430x90x130	430x90x140	510x120x140	530x120x140



**DMP25CNC-3A-2S**  
25/38/50/63/75/89/115/130/168/219

	DMP25CNC-3A-2S	DMP38CNC-3A-2S	DMP50CNC-3A-2S	DMP63CNC-3A-2S	DMP75CNC-3A-2S	DMP89CNC-3A-2S
Min bending R for carbon pipe is:1.5D	ø25.1x1.6t	ø38.1x2.0t	ø50.8x2.0t	ø63.5x2.0t	ø76.2x2.0t	ø88.9x2.0t
Max feed distance	1300mm	2100mm	2400mm	2500mm	2800mm	3000mm
Feeding method	/					
Max R for bending	175mm	175mm	250mm	250mm	300mm	300mm
*Max angle for bending	185°	185°	185°	185°	185°	185°
Bending process for every pipe	16	16	16	16	16	16
Max bending group	500	500	500	500	500	500
working rate	Bending Rate	Max.45	Max.45	Max.40	Max.35	Max.30
	Rotary Rate	Max.270	Max.270	Max.270	Max.270	Max.180
	Feeding Rate	Max.900	Max.900	Max.900	Max.900	Max.700
	Bending Angle	± 0.15°	± 0.15°	± 0.15°	± 0.15°	± 0.15°
working Accuracy	Rotary Angle	± 0.1°	± 0.1°	± 0.1°	± 0.1°	± 0.1°
	Feeding Length	± 0.1mm	± 0.1mm	± 0.1mm	± 0.1mm	± 0.1mm
	Data Input Method	( Y.B.C )	( Y.B.C )	( Y.B.C )	( Y.B.C )	( Y.B.C )
Rotary Servo motor Power	400w	850w	850w	850w	850w	1300w
Feeding Servo motor Power	850kw	1.0kw	1.0kw	1.5kw	2kw	2kw
Electric Motor Power	4kw	4kw	5.5kw	5.5kw	7.5kw	11kw
Weight	1100kg	2100kg	2400kg	2800kg	3800kg	4200kg
Size (LxWxH) ( cm )	280x70x130	400x110x130	430x100x150	450x100x150	520x120x140	560x120x160

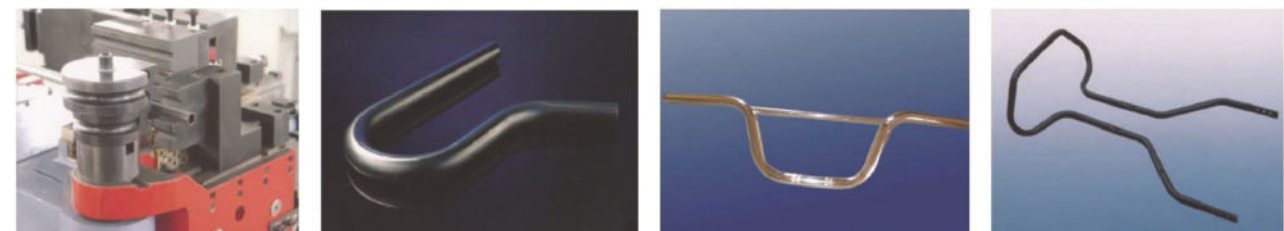



## CNC Pipe Bending Machine



**DMP38CNC-5A-3S**

25/38/50/63/75/89/115/130/168

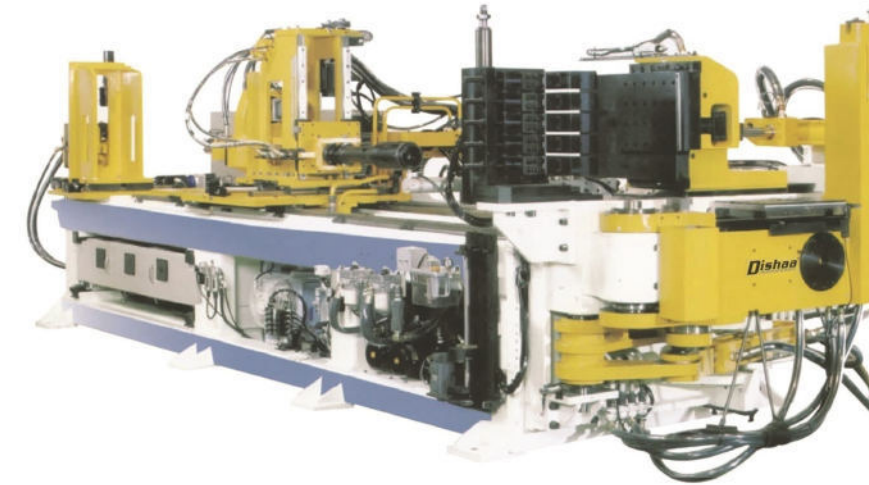

**DMP130CNC-6A-4S**

25/38/50/63/75/89/115/130/168

CNC PIPE BENDING

CNC PIPE BENDING

	1.DMP25CNC-5A-3S 2.DMP25CNC-5A-4S	1.DMP38CNC-5A-3S 2.DMP38CNC-5A-4S	1.DMP50CNC-5A-3S 2.DMP50CNC-5A-4S
Max bending capacity	ø25mmx1.6mm	ø38mmx2mm	ø50mmx3mm
Max R for bending	R100mm	R180mm	R250mm
Max feeding distance	2200mm	2500mm	3000mm
Max angle for bending	190°	190°	190°
working speed	Bending speed	Max.200	Max.150
	Rotary speed	Max.200	Max.200
	Feeding speed	Max.1000mm	Max.1000mm
working Accuracy	Bending Angle	± 0.1°	± 0.1°
	Rotary Angle	± 0.1°	± 0.1°
	Feeding Length	± 0.1mm	± 0.1mm
Data Input Method	1.(X.Y.Z) 2.(Y.B.C)	1.(X.Y.Z) 2.(Y.B.C)	1.(X.Y.Z) 2.(Y.B.C)
Bending method	2kw	5kw	1.; 5kw
Rotary Servo motor Power	400w	750w	750w
Feeding Servo motor Power	750w	1kw	1kw
Max bends every pipe	1.16 (PLC) 2. 33	1.16 (PLC) 2. 33	1.16 (PLC) 2. 33
Max bending storage	1.1000 (PLC) 2. 2	1.1000 (PLC) 2. 2	1.1000 (PLC) 2. 2
Electrl motor power	3kw	4kw	5.5kw
Maximum system pressure (adjustable)	12Mpa	12Mpa	12Mpa
Bending mold gap	Max.35mm	Max.50mm	Max.75mm
Weight	1000kg	1500kg	3500kg
Size (cm)	320x75x110	450x90x140	460x110x150



**Properties**

Multi-S series bender is a multi-mode pipe bender, which is equipped with servo motor or proportional servo valve based on different models and is capable of multi-axis control, with bending capacity less than 325mm in pipe diameter. According to different user needs, multiple bending capacities can be provided, for example, elbow boosting of 1D materials and end bend boosting skill. Manufacturing of spare parts for such industries as parts necessary for auto industry, healthy sports equipment, furniture, medical apparatus and instruments, engineering construction machinery and other industries.

Four sets of moulds can be simultaneously loaded to rapidly install and replace different bending radii; servo control system, small amount of hydraulic oil, and oil temperature not too high 1-4 layers of bending moulds can be added to CNC5 axis motor servo control; early pulling of core can be set for core rod

Each layer of moulds can independently control auxiliary boosting speed of guided mould; equipped with adjustable wrinkle-proof plate holder CNC numerical value controls and matches high mechanical accuracy, and improves bending speed and accuracy

Direct feeding or feeding by clamping can be chosen  
Equipped with IPC (industrial computer) and touch control screen  
Can be equipped with interference simulation software, and the operator can input parameters to view if there is any collision or error (optional)

	DMP63CNC-5A-3S	DMP75CNC-5A-3S	DMP89CNC-5A-3S	DMP115CNC-5A-3S
Max bending capacity	ø63mmx4mm	ø75mmx4mm	ø89mmx8mm	ø115mmx8mm
(1) Max R for bending	R250mm	R250mm	R250mm	R350mm
(2) Min bending radius				
Max angle for bending	190°	190°	190°	190°
(3) Max feeding distance	3000mm	3000mm	3000mm	3000mm
Feeding method				
working speed	Bending speed	Max.85	Max.40	Max.30
	Rotary speed	Max.200	Max.160	Max.160
	Feeding speed	Max.1000mm	Max.800mm	Max.800mm
working Accuracy	Bending Angle	± 0.1°	± 0.1°	± 0.1°
	Rotary Angle	± 0.1°	± 0.1°	± 0.1°
	Feeding Length	± 0.1mm	± 0.1mm	± 0.1mm
Data Input Method	1.(X.Y.Z) 2.(Y.B.C)	1.(X.Y.Z) 2.(Y.B.C)	1.(X.Y.Z) 2.(Y.B.C)	1.(X.Y.Z) 2.(Y.B.C)
Bending method	1kw	2kw	5kw	5kw
Rotary Servo motor Power	750w	1kw	1.5kw	1.5kw
Feeding Servo motor Power	1kw	1.5kw	2kw	3.5kw
Max bends every pipe		1.16 (PLC) 2. 33		
(4) Max bending storage		1.1000 (PLC) 2. 2		
Electrl motor power	5.5kw	7.5kw	11kw	22kw
Maximum system pressure (adjustable)	12Mpa	12Mpa	14Mpa	14Mpa
(5) Bending mold gap	Max80mm	Max90mm	Max100mm	Max110mm
Weight	3800kg	4500kg	5500kg	8000kg
Size (cm)	5200x1300x1750	5200x1350x1230	5650x1350x1360	5700x1350x1400



## Manual Hydraulic Pipe Bending Machine



### Product Description

- Simple manual hydraulic operation for easy use.
- Completely manual hydraulic operation so external power is not needed.
- Heavy-duty hydraulic cylinder capable of bending schedule 40 pipe.
- Cold bending pipes only in one turn. Up to 90 degree, hydraulic equipment makes more precise bending.
- Pipe stands are also included for better bending experience.
- Suitable for cold bending of thick-walled pipes(gas,water and steam pipes, non-heated black iron pipes, galvanized pipes), up to 90°

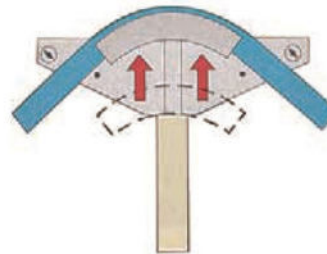

Bending illustration

### Specifications

Model No.	Max	Max stroke	Bending dies	Pipe wall thickness	G. W.	Dimension
DPB-2J	13T	250mm	1/2", 3/4", 1", 1 1/4", 1 1/2", 2"	2.75-4.5mm	53kg	73×32×20cm
DPB-3J	20T	290mm	1/2", 3/4", 1", 1 1/4", 1 1/2", 2", 2 1/2", 3"	2.75-5mm	105kg	94×40×21cm
DPB-4J	23T	370mm	1/2", 3/4", 1", 1 1/4", 1 1/2", 2", 2 1/2", 3", 4"	2.75-6mm	155kg	118×46×23cm

## Electric Hydraulic Pipe Bending Machine



### Product Description

- Electric hydraulic bender up to 4" pipe.
- Using range: applicable to general pipe, conductor pipe, gas pipe, the thick steel pipe, etc. , bending angle up to 90 degree.
- All bending dies are made of cast iron than ordinary grey cast iron. With high strength, good toughness and plasticity, more resistant to use, not easy to break.
- Fast setup and disassembly, convenient removing with bottom wheels.
- Stands are optional instead of bottom wheels.
- Equipped with HL-630A one-way pumps for single-acting applications.
- Suitable for cold bending of thick-walled pipes(gas,water and steam pipes, non-heated black iron pipes, galvanized pipes), up to 90°

optional tripod stand

### Specifications

Model No.	Max pressure	Max stroke	Pump	Bending dies	Pipe wall thickness	G. W.	Dimension
DPB-2D	13T	250mm	750W	1/2", 3/4", 1", 1 1/4", 1 1/2", 2"	2.75-4.5mm	74kg	96×35×27cm
DPB-3D	20T	290mm	750W	1/2", 3/4", 1", 1 1/4", 1 1/2", 2", 2 1/2", 3"	2.75-5mm	126kg	118×46×27cm
DPB-4D	23T	370mm	750W	1/2", 3/4", 1", 1 1/4", 1 1/2", 2", 2 1/2", 3", 4"	2.75-6mm	174kg	118×46×32cm



## Profile Bending Machine



power by manual

**DRBM10**

Model	DRBM10		
		Size(mm)	Min Dia.(mm)
Max. capacity (mm) (one set standard roller)		20x5	190
		30x10	500
		20x5	160
		50x10	400
		10x10	160
		20x20	500
Packing size (cm)	50x48x68(body) 87x77x34(stand)		
N.W./G.W.	153/170kg		

- ▶ Special cast frame
- ▶ Shafts are hardened with special steel material
- ▶ Rollers are special steel material hardened and grounded
- ▶ Gears milled with full material
- ▶ Optional rollers for choice



Model	DRBM30HV			
Dia. of roller	30mm			
Power	0.75kW/1HP			
Spindle speed	9r/min			
Packing size	120X75X121cm			
N.W./G.W.	244/282kgs			
Capacity	Size (mm)	Min dia. (mm)	Article No.	
	40x40x3	1000	one set standard roller	
	50x15	350		
	50x30x3	1200		
	Φ 15 Φ 20 Φ 25 Φ 30	600	HV30-15-4	
	40x40x2 40x40x3 40x40x4 40x40x5	400	HV30-15-5	
	40x40x2 40x40x3 40x40x4 40x40x5	400	HV30-15-6	
	50x50x2 50x50x3 50x50x4 50x50x5	400	HV30-15-7	
	50x25x2 50x25x3 50x25x4 50x25x5	300	HV30-15-8	
	50x25x2 50x25x3 50x25x4 50x25x5	400	HV30-15-9	
	50x25x2 50x25x3 50x25x4 50x25x5	300	HV30-15-10	
	Φ 35x2 Φ 40x2 Φ 45x2 Φ 50x2 Φ 55x2 Φ 60x2	1000	HV30-15-11	



**DRBM30**

- ▶ Horizontal operation
- ▶ With standard foot pedal

Model: DMPR-3  
Item No.: 376001  
Ring size rang: 1" to 3"  
Round steel capacity: 1/4"  
Flat steel capacity: 1" to 3/16"  
Handle: 13-1/2"  
N.W./G.W.: 6/7 kg  
Packing size:  
36x20x21 cm



**DMPR-3**

Model	DRBM30			
Dia. of roller	30mm			
Power	1.1kW/1.5HP			
Spindle speed	9r/min			
Packing size	82x62x126cm			
N.W./G.W.	270/320kgs			
Capacity	Size	Min dia. (mm)	Article No.	
	φ 20x1	500	391001-01	
	φ 30x1	800	391001-02	
	φ 16	400	391001-01	
	20x20x1	800	391001-03	
	30x30x1	900	391001-04	
	20x10	320	391001-05	
	30x10	320		



**DRBM30HV**

- ▶ Horizontal and vertical operation
- ▶ With standard foot pedal

PROFILE BENDING

PROFILE BENDING



## Profile Bending Machine



**DRBM40HV**



**DRBM50**

Model	DRBM40HV		DRBM50	
Dia. of roller(mm)	Φ40		Φ50	
Power	1.5kW/2HP		2.2kW/3HP	
Spindle speed	9.3 r/min		13 r/min	
Packing size (cm)	127X89X158		100X82X155	
N.W./G.W. (kg)	425/495		450/582	
Capacity	Size(mm)	Min Dia.(mm)	Size(mm)	Min Dia.(mm)
	50x10 20x6	600 800	60x10 40x10	500 650
	60x20 30x6	800 1250	100x15 60x10	920 1150
	30x30 10x10	650 1100	35x35 20x20	600 780
	50x6 30x3	600 500	60x7 50x5	750 500
	50x6 30x3	600 500	60x7 50x5	750 700
	60x40x6 30x15x4	600 900	80x45x6 65x40x5	600 550
	60x40x6 30x15x4	600 900	80x45x6 65x40x5	650 550
	50x5 30x4	500 500	60x5 50x5	500 500
	50x5 30x4	500 500	60x5 50x5	700 700
	Φ30 Φ10	650 1100	Φ35 Φ30	600 650
	50x50x2.5 30x30x2	700 800	60x60x3 40x40x3	600 500
	50x25x2.5 40x20x2	800 1000	70x50x3 50x40x3	1200 800

\* All the above processing capacities can be finished by one set of standard combination roller

► Special Roller

Model	DRBM40HV		DRBM50	
Profile	Size(mm)	Min Dia.(mm)	Size(mm)	Min Dia.(mm)
	30x2 35x2 40x2 45x2 50x2 55x2 60x2 65x2 70x2	700	30x2 35x2 40x2 45x2 50x2 55x2 60x2 65x2 70x2	600

We can design the rollers for you as per your special requirements. And we can make the rollers in various materials such as nylon.

Model	DHRBM65	
Dia. of roller(mm)	Φ65	
Power	2.25kW	
Spindle speed	9.3 r/min	
Packing size (cm)	125x115x180	
N.W./G.W. (kg)	720/920	
Capacity	Size(mm)	Min Dia.(mm)
	80x25 40x10	600 500
	120x25 50x10	600 400
	50 20	600 400
	80x40x7 40x40x5	500 400
	80x40x7 40x40x5	400 360
	100x50x6 50x40x5	600 500
	100x50x6 50x40x5	600 500
	70x6 40x5	500 400
	70x6 40x5	600 500
	Φ50 Φ20	600 400
	70x70x3 30x30x3	900 500
	80x40x3 50x30x2	800 500

\* All the above processing capacities can be finished by one set of standard combination roller

► Special Roller

Model	DRBM40HV	
Profile	Size	Min Dia.(mm)
	3-1/2" x 2" 2-1/8" x 2"	900 500
	Φ100 x 2mm Φ60 x 2mm	1000 500

We can design the rollers for you as per your special requirements. And we can make the rollers in various materials such as nylon.



**DHRBM65**

- Steel-welded construction frame
- with hydraulic motor
- Mobile control panel
- Top roll hydraulic moveable
- One standard combination roller
- Horizontal and Vertical working position



## Threading Machine



Model No.	Description	Power Watts	Spindle Speed RPM	Pipe Threading Capacity		N.W (kg)
				in.	mm.	
SQ50B1	110V, 60Hz	750	23	1/2-2	15-50	60
SQ50B1	220V, 50Hz	750	23	1/2-2	15-50	60
SQ80D1	110V, 60Hz	750	26/11	1/2-3	15-80	100
SQ80D1	220V, 50Hz	750	26/11	1/2-3	15-80	100
SQ100D1	110V, 60Hz	750	24/10	1/2-4	15-100	140
SQ100D1	220V, 50Hz	750	24/10	1/2-4	15-100	140
SQ50C1	110V, 60Hz	900	23	1/2-2	15-50	60
SQ50C1	220V, 50Hz	900	23	1/2-2	15-50	60
SQ80D	110V, 60Hz	900	26/11	1/2-3	15-80	100
SQ80D	220V, 50Hz	900	26/11	1/2-3	15-80	100
SQ100D	110V, 60Hz	900	24/10	1/2-4	15-100	140
SQ100D	220V, 50Hz	900	24/10	1/2-4	15-100	140
SQ50A	110V, 60Hz	1000	28	1/2-2	15-50	60
SQ50A	220V, 50Hz	1000	28	1/2-2	15-50	60
SQ80A	110V, 60Hz	1100	28/14	1/2-3	15-80	100
SQ80A	220V, 50Hz	1100	28/14	1/2-3	15-80	100
SQ100A	110V, 60Hz	1100	28/12	1/2-4	15-100	140
SQ100A	220V, 50Hz	1100	28/12	1/2-4	15-100	140

## Pipe Support Stand



- The heavy-duty adjustable pipe stands are available in many applications with capacity from 1/8"-12" (3mm-300mm); suitable for use with threading machine, roll groovers, etc.
- 1107X and 1109X are the more heavy-duty adjustable pipe stands which are upgraded from 1107 and 1109. The screw-like elevator tube and thicker lock ring bring more higher Max. Loading Weight capacity for the stands to make them suitable for supporting more heavy pipes or solid bars safely.



A-Ball Transfer Head



B-Ball Transfer Head

### V Head Pipe Stands

Model No.	Description	Height Adjustment Low-High		Max. Pipe Capacity		Max. Weight Capacity		N.W
		in.	cm	in.	mm	lb.	kg	
1107	V Head High Pipe Stand	28-52	71-132	12	300	2500	1134	14.5
1107S	V Head Low Pipe Stand	24-40	61-102	12	300	2500	1134	11.5
1107X	V Head High Pipe Stand	28-52	71-132	12	300	4000	1814	14.5

### Roller Head Pipe Stand

Model No.	Description	Height Adjustment Low-High		Max. Pipe Capacity		Max. Weight Capacity		N.W
		in.	cm	in.	mm	lb.	kg	
1109	Roller Head Pipe Stand	32-55	82-140	12	300	1000	454	15
1109X	Roller Head Pipe Stand	32-55	82-140	12	300	2500	1134	15

### Ball Transfer Head

Model No.	Description	Max. Pipe Capacity		Max. Weight Capacity		N.W
		in.	mm	lb.	kg	
A	Ball Transfer Head only	12	300	1000	454	1.5
B	Ball Transfer Head only	12	300	2000	900	2.8



## Material Handling Equipment

### HAND PALLET TRUCK

- Forks are processed with whole press forming technology and coated with powder painting, torsion and fading-resistant.
- Excellent whole casting hydraulic pump and welded pump for your choice, robust and durable, with fine control of lowering speed and overload valve. Integrated pump is easy to maintain.
- The wheel material has Nylon, PU, Rubber, Iron to choose from. The guide wheel is optional to ensure easier operation.
- Ergonomically designed handle with comfortable rubber grip allows the optimized safety.



Polyurethane

Nylon

MODEL		2500	3000	5000
Capacity	Kg	2500	3000	5000
Min. fork height	Mm	80		100
Max. fork height	Mm	190		210
Steering wheel	Mm	Nylon/PU		180x60
Load roller	Mm	Nylon/PU		88x106
Each fork width	Mm	150		180
Each fork thickness	Mm	3	4	5
Width	Mm	550/685		700
Length	Mm	1150/1220		1310
Weight	Kg	68	75	200

### SEMI ELECTRIC STACKER



Joystick



Operating Panel



Foot Brake



Customized Leg (Optional)

MODEL		DSM-10	DSM-15	DSM-20	
Features	Drive system	Battery			
	Driving mode	Standing			
	Load Capacity	Q	Kg	1000/1500/2000	
	Load Center	C	mm	500	
Weight	Weight(With battery)	Kg	345/390/410/430		
Wheel	Material	PU/NYLON			
Size	Lifting Height	H3	mm	1600/2000/2500/3000/3500	
	Lowest Mast	H1	mm	2090/1590/1840/2090/2340	
	Max.Height when operating	H4	mm	2090/2740/3240/3740/4240	
	Min. Height of Fork	s	mm	85	
	Length	L	mm	1740	
	Width	B	mm	770	
	Fork Length	L1	mm	1070	
	Fork Outside Width	B1	mm	550/680	
	Fork Inside Width	B2	mm	305	
	Min.Turning Radius	Wa	mm	1500	
	Wheelbase	Y	mm	1420	
	Motor	Lifting Motor	KW	DC/2.2	
	Battery	Capacity	V/Ah	12/120	

HAND PALLET TRUCK

STACKER



## Material Handling Equipment

### FULL ELECTRIC WALKIE STACKER

- With explosion-proof valve at the bottom of cylinder, even if the pipe burst, the mast will not rapidly decline.
- There is a turtle speed control button on the behind of control handle, which is more economic when operating.
- Curtis controller.
- Operating handle is on the side, allowing operators to work with greater vision.

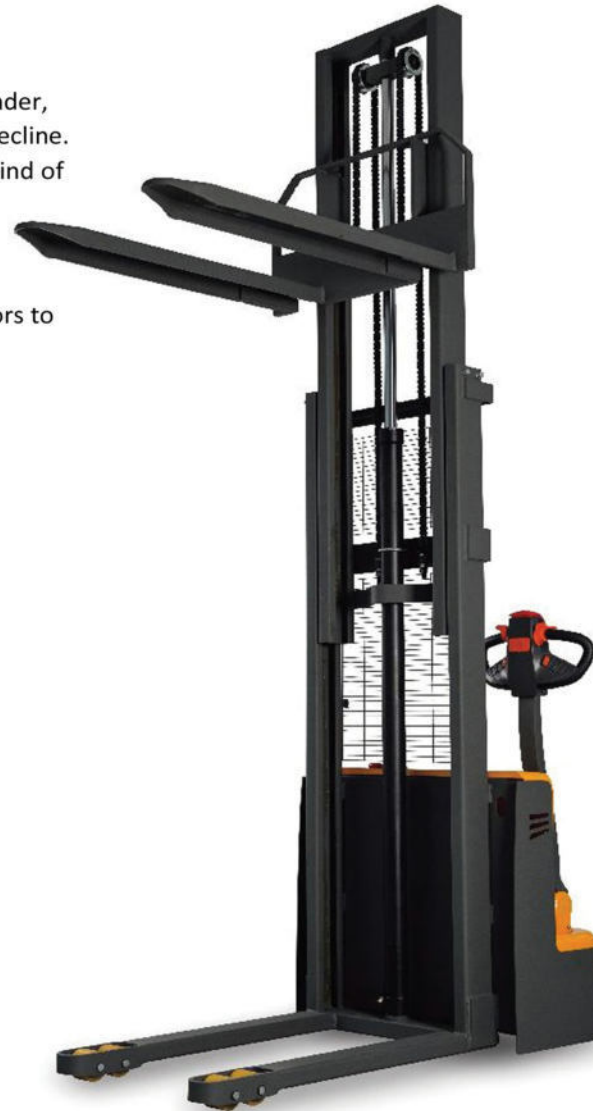

#### Optional Configuration

- Customized length of fork & width of legs
- Forged fork
- Specially used in cold storage area.



Cylinder



Control Handle



Operating Panel



Customized Led (Optional)

Model	CDD I-12		CDD II-16	
Features	Motor		Electric( Battery)	
	Driving Mode		Walkie	
	Load Capacity	Q(kg)	1200/1600	
	Load Center	C(mm)	500	
Weight	Weight (with battery)	CDD I-12 Kg	470/485/505/520	
		CDD II-16 Kg	495/510/532/553	
Wheel	Wheel Material		polyurethane	
Size	Lift Height	h3(mm)	1600/2000/2500/3000	
	Lowered Mast Height	h1(mm)	2080/1580/1830/2080	
	Max. Mast Height when operating	h4(mm)	2080/2730/3230/3730	
	Lowest fork height	S(mm)	≤90	
	Length	L(mm)	1770	
	Width	B(mm)	850	
	Fork Length	L1(mm)	1070	
	Wheelbase	Y(mm)	1250	
	Fork Outside Width	B1(mm)	680	
	Fork Inside Width	B2(mm)	305	
Min. Turning Radius	Wa( mm)	1390		
Parameter	Drive Speed, Empty/Full load		mm/s	5.0/5.0
	Lift Speed, Empty/Full load		mm/s	140/135
	Lift Speed, Empty/Full load		mm/s	150/155
	Maximum gradient, Empty/ Full load		%	7/5
	Service brake		Electromagnetic	
Motor	Drive motor		DC	
	Power	Kw	0.75	
	Lifting motor		DC	
Battery	Power		Kw	2.2
	Voltage		V	DC24V
	Capacity		Ah	2*70/2*80
Others	Noise Level DIN12053		dB	< 70



# Gallery

