

DishaaTM

CUTTING, DRILLING
& BEVELING

CONTACT US

P.O. BOX: 80899, Dubai, UAE

Mob: +971 50 9696 477

Email: sajith@dishaagroup.com

Website: www.dishaagroup.com

Pipe Hole Cutter



JK114

Product Description

- Jk114 is designed fo cut holes up to 114mm into steel pipe. The multiple holes sizes allow the use of fittings for branching unpressurized pipe lines.
- Light weight for easy transportation, ideal for the hole cutting in small sizes. Induction motor ensure quiet working performance.

Specifications

- **Cutting Capacity:** up to 114mm
- **Pipe Mounting Capacity:** 1 1/4"-8" (OD: 42mm-219mm)
- **Drill Chuck Capacity:** 3-16mm
- **Drill Chuck Speed:** 110RPM (no load)
- **Motor:** induction, 550W
- **Height:** 513 mm
- **Length:** 260 mm
- **Width:** 248 mm

Ordering Information

Catalog No.	Model No.	Description	N.W	G.W	Packing(cm)
309201	JK114	220V,50HZ	16.0kg	17.2kg	55×30×35
309202	JK114	110V,60HZ	16.0kg	17.2kg	55×30×35



Pipe Hole Cutter



4 Guide Rods

2 Chain Assembly

JK150

Product Description

- The Hongli Model JK150 pipe hole cutter is designed to cut holes up to 152 mm into steel pipe.
- The multiple hole sizes allow the use of fittings for branching unpressurized pipe lines.
- The JK150 has a 5/8" (16 mm) capacity drill chuck to accommodate all sizes of hole saws and hole saw arbors.
- An integral motor and gear reduction optimizes performance of large diameter hole saws.
- The dual-side feed handle allows the operator to use the Hole Cutting Tool from either the left or right side.

Specifications

- **Cutting Capacity:** Up to 152 mm
- **Pipe Mounting Capacity:** 1 1/4" - 12" (OD: 42mm-323mm)
- **Drill Chuck Capacity:** 3-16mm
- **Drill Chuck Speed:** 110 RPM (no load)
- **Motor:** universal, 1500W

Ordering Information

Catalog No.	Model No.	Description	N.W	G.W	Packing(cm)
310202	JK150	220V,50HZ	20.0kg	22.0kg	40×30×35
310201	JK150	110V,60HZ	20.0kg	22.0kg	40×30×35

Hole saws



arbor



Product Description

- Excellent performance and long-lasting life.
- Bi-metal construction with teeth made from specially hardened M3 or M42 high speed steel. The varying teeth height and gullet sizes result in much faster cutting and longer life. Suitable for various material like mild steel, tool and stainless steel, brass, aluminum, wood. Size ranges from 14mm to 210mm.
- Depth of cut: 38mm
- Use high quality thread cutting oil on all metal except cast iron

Ordering Information

Catalog No.	Sizes (mm)	Applicable arbor
1511010	14	A1
1511210	16	A1
1511310	17	A1
1511510	19	A1
1511610	20	A1
1511710	21	A1
1511810	22	A1
1512010	24	A1
1512110	25	A1
1512310	27	A1
1512410	29	A1
1512510	30	A1
1512610	32	B1
1512710	33	B1
1512810	35	B1
1512910	37	B1
1513010	38	B1
1513110	40	B1
1513210	41	B1
1513310	43	B1

Catalog No.	Sizes (mm)	Applicable arbor
1513410	44	B1
1513510	46	B1
1513610	48	B1
1513710	51	B1
1513810	52	B1
1513910	54	B1
1514010	57	B1
1514110	59	B1
1514210	60	B1
1514310	64	B1
1514410	65	B1
1514510	67	B1
1514610	68	B1
1514710	70	B1
1514810	73	B1
1514910	76	B1
1515010	79	B1
1515110	83	B1
1515410	86	B1
1515510	89	B1

Catalog No.	Sizes (mm)	Applicable arbor
1515610	92	B1
1515910	95	B1
1516010	98	B1
1516410	102	B1
1516710	105	B1
1516810	108	B1
1516910	111	B1
1517210	114	B1
1517910	121	B1
1518010	127	B1
1518110	133	B1
1518210	140	B1
1518310	146	B1
1518410	152	B1
1518510	160	B1
1518610	165	B1
1518710	168	B1
1518810	177	B1
1518910	200	B1
1519010	210	B1



Hydraulic Power Pipe Cutters

QG8C-A

Product Description

- The Model QG8C-A Hydraulic Power Pipe Cutter cuts 2" to 8" schedule 10/40 steel pipe, galvanized pipe at the job site or in the shop. The operator controls the feeding rate by pumping the hydraulic pump throughout the operation.
- The QG8C-A cuts pipes with clean cutting edge, no spark, dust or open flame. The processed pipes can be threaded or grooved with no extra processing. An induction motor insures very quiet operation.

Features

- Easily cuts by displacing instead of removing pipe material.
- No abrasive dust, dangerous spark, or open flame.
- Quickly cuts steel pipe with minimal burr.
- Great for cutting pipe for groove joining.
- Heavy-duty design is perfect for field or shop use.
- Quiet operation.
- Hongli Reinforced Alloy cutting Wheel which is suitable to squeeze.

Specifications

- **Cutting Capacity:** 2" to 8" schedule 10/40
- **Motor:** 550W induction, 50/60Hz
- **Spindle Speed:** 24 RPM
- **Switch:** ON/OFF heavy duty switch

Ordering Information

Catalog No.	Model No.	Description	N.W(kg)
307201	QG8C-A	Hydraulic Power Pipe Cutter, 110V/60Hz	65
307202	QG8C-A	Hydraulic Power Pipe Cutter, 220V/50Hz	65
Accessories			
	--	Cutting Wheel	1.25
	--	Ball Bearing Pipe Support	6



Reinforced Alloy Cutting Wheel



Ball Bearing Pipe Support



Hydraulic Power Pipe Cutters



QG12C

Product Description

- The Model QG12C Hydraulic Power Pipe Cutter offers 2" to 12" schedule 10/40 cutting range. Utilizing displacement type cutter wheel technology. The operator controls the feeding rate by pumping the hydraulic pump throughout the operation. The QG12C cuts pipe with clean cutting edge, no sparks, dust or open flame. The processed pipes which by QG12C can be threaded or grooved with no extra processing. An induction motor insures very quiet operation.

Features

- Easily cuts by displacing instead of removing pipe material.
- No abrasive dust, dangerous sparks, or open flame.
- Quickly cuts steel pipe with minimal burr.
- Great for cutting pipe for groove joining.
- Heavy-duty design is perfect for field or shop use.
- Quiet operation.
- Hongli Reinforced Alloy cutting Wheel which is suitable to squeeze.

Specifications

- **Cutting Capacity:** 2" to 12" schedule 10/40
- **Motor:** 750W induction, 50/60Hz
- **Spindle Speed:** 24 RPM
- **Switch:** ON/OFF heavy duty switch



Reinforced Alloy Cutting Wheel



Ball Head Pipe Support

Ordering Information

Catalog No.	Model No.	Description	N.W(kg)
308203	QG12C	Hydraulic Power Pipe Cutter, 110V/60Hz	120
308204	QG12C	Hydraulic Power Pipe Cutter, 220V/50Hz	120
Accessories			
	--	Cutting Wheel	1.25
	--	Ball Head Pipe Support	



C-Narrow Design Pipe Beveling Machine

ISC

Product Description

- This machine is effective, ideal and reliable solution to precisely square cut and bevel for all types of metal pipes/tubes. All saw-bladed pipe cutters with precise, square and clean cut, which save any additional preparation work on the cut-off face for orbital welding.
- The cut/beveled pipe is free from burr and deformation because of high quality saw blades. It is the best choice for direct S.S pipe welding on catering, pharmacy, semiconductor optoelectronics, biology, chemical industry, oil and gas, water treatment, shipbuilding, electric power industry, etc.



Specifications

- Compact structure, designed to bevel the pipe in the narrow space.
- Pipe out-mounted, self centering, secured clamping, easy to operate.
- Aluminum body, light weight, suitable for working aloft.
- High quality beveling tool, can process different grades of carbon steel, alloy steel, stainless steel and so on.
- More choice for the driven model, electric or pneumatic, widely applicable.
- Apply to pipe end beveling process of water pipe, heater boiler and thermal power plant.
- Electric: Driven by low-energy consumption electric motor 110V or 220V, 50-60Hz
- Pneumatic: Drive by pneumatic motor. Air working pressure: 0.6-0.8Mpa, Air Consuming flux: 650-960L/min

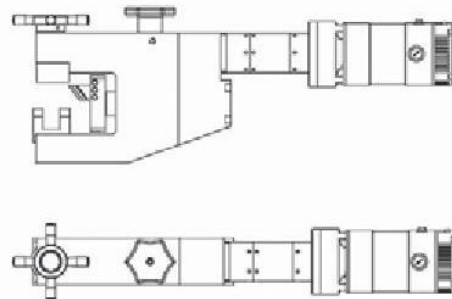

Beveling Types

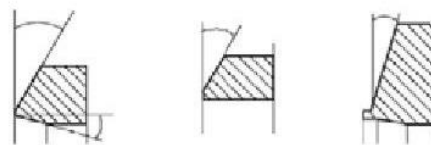

- other bevel angles or alloy steel, cast steel, please consult us.

Technical Parameter

Model No.	Size	Working range (OD mm)	Wall thickness(mm)	"Tool stroke (mm)"	Rated Power (KW)	Rotating Speed(rpm)
Electric: ISC Pneumatic: TSC	53	8-53	≤ 8	0-11	0.9	58
	63	20-63	≤ 12	0-11	0.9	55
	73	25-73	≤ 12	0-11	0.9	54
	83	30-83	≤ 12	0-11	1.4	43
	108	50-108	≤ 12	0-11	1.4	42

Split Frame Pipe Cutting and Beveling Machine

Product Description

- Split frame technology, easy to install in pipeline.
- Out mounted, clamping by multipoint jaws.
- Cold cutting, don't influence the pipe's material.
- Auto feed, Cutting and Beveling the pipe at the same time, cost effective.
- Variety of beveling shape: "U", "V", "J", double "V" compound bevels.
- Can process material: carbon steel, alloy steel, stainless steel
- Pipeline construction site, beveling process for all the size of pipes & pressure vessels & steam generator.
- Application: petroleum, chemical, natural gas, power supply construction, boiler and nuclear power.
- Four types of driven motors :Electric, Pneumatic, Numerical Controller and Hydraulic.

Beveling Types

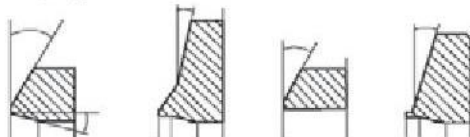

- Other bevel angles or alloy steel, cast steel, please declare before order.

Tools

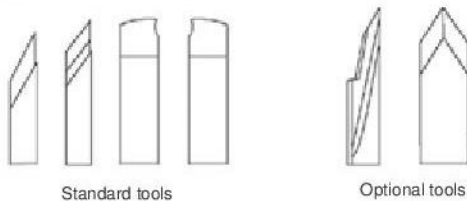

- Standard tools attached (high speed steel, wall thickness≤25mm), If customers need other degrees cutting tools or wall thickness >25mm, please inform us before order.

Specifications

- Electric: Driven by low-energy consumption electric motor. 110V or 220V, 50-60Hz
- Pneumatic: Drive by pneumatic motor. Air working pressure: 0.6-0.8Mpa, Air Consuming flux: 650-960L/min

Electric Drive



ISD SERIES

Pneumatic Drive



ISF SERIES

Split Frame Pipe Cutting and Beveling Machine

Specifications

- Numerical controller: Driven by the high-power servo motor and PLC control system. Timing range: 0-20 RPM, Power 2.0-5.5KW, 220-230V, 50-60Hz.
- Hydraulic: Driven by hydraulic motor, Rated pressure: 16Mpa, Rate Flux; 25L/min, output torque 260 NM, Electric power: 7.5KW, 380V-3Ph.

Machine Body and Material

- Standard Model: Alloy steel with ionic treatment. The weight is a little heavy, but sturdy and durable.
- Light Model: Aerospace grade Aluminum alloy or Hollow-out alloy steel. Light weight and suitable for high-altitude operation.

Numerical Controller



SKD SERIES

Hollow-out Alloy Steel



Hydraulic Drive



HYD SERIES

Aluminum Alloy



CUTTING, DRILLING & BEVELING



Dishaa™

the real manufacturer

Standard

Model No.	Size(mm)	Capacity (OD mm)		Wall thickness (mm)		Rotating Speed (rpm)
		OD(mm)	OD(inch)	Single Operation	Multi Operation	
Electric:ISD Pneumatic:ISF N C:SKD Hydraulic:HYD	90	Φ10-90	3/8"-3"	≤25	-	34
	168	Φ25-168	1"-6"	≤25	≤50	24
	219	Φ50-219	2"-8"	≤25	≤50	23
	273	Φ114-273	4"-10"	≤25	≤75	23
	323	Φ168-323	6"-12"	≤25	≤75	23
	355	Φ177-355	8"-14"	≤25	≤110	23
	406	Φ254-406	10"-16"	≤25	≤110	22
	457	Φ323-457	12"-18"	≤25	≤110	20
	508	Φ355-508	14"-20"	≤25	≤110	20
	559	Φ406-559	16"-22"	≤25	≤110	14
	610	Φ457-610	18"-24"	≤25	≤110	14
	762	Φ610-762	24"-30"	≤25	≤110	13
	914	Φ762-914	30"-36"	≤25	≤110	11
	1066	Φ980-1066	36"-42"	≤25	≤110	10
	1160	Φ980-1160	38"-44"	≤25	≤110	9
	1240	Φ1040-1240	40"-48"	≤25	≤110	9
	1300	Φ1150-1300	45"-51"	≤25	≤110	8
	1540	Φ1320-1540	52-60"	≤25	≤110	5
	1700	Φ1500-1700	59-67"	≤25	≤110	4
	1910	Φ1700-1900	67-75"	≤25	≤110	4
2100	Φ1905-2100	75"-83"	≤25	≤110	3	
2310	Φ2100-2310	83"-91"	≤25	≤110	2	

CUTTING, DRILLING & BEVELING

Machine Body Size

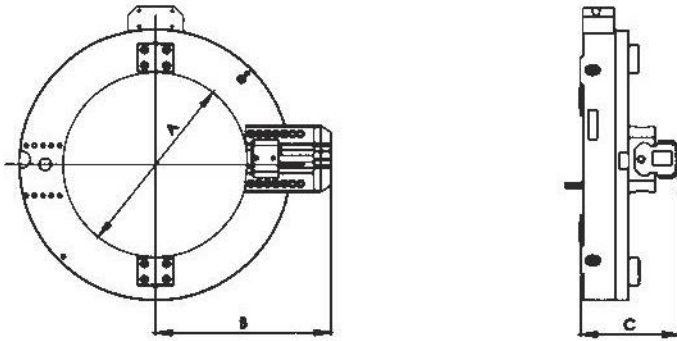

Model No.	90	168	219	273	323	355	406	457	508	558	610
A(mm)	90	180	227	281	333	365	420	470	516	565	620
B(mm)	176	235	260	289	318	331	386	386	409	434	461
C(mm)	161	190	195	195	195	195	195	195	195	195	195

Model No.	762	914	1066	1160	1240	1300	1540	1700	1910	2100	2300
A(mm)	770	930	1080	1170	1240	1306	1550	1750	1950	2150	2350
B(mm)	536	623	698	802	837	870	992	1092	1292	1292	1392
C(mm)	195	195	195	195	215	215	215	215	235	235	235

Beveling Types

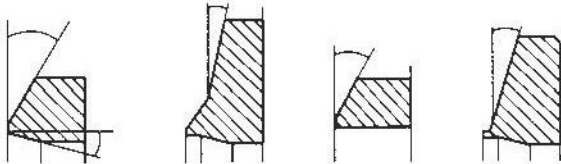

Other bevel angles or alloy steel, cast steel, please declare before order.

Tools

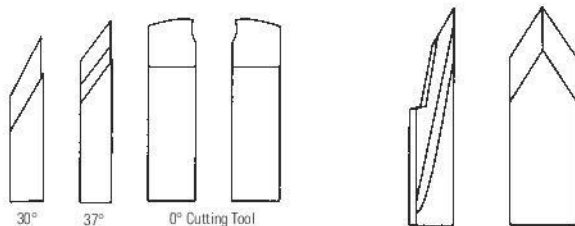

Standard tools

Optional tools

Standard tools attached (high speed steel, wall thickness ≤25mm), If customers need other degrees cutting tools or wall thickness 25mm, please inform us before order.

T-Type Beveling Machine

Product Description

- Inner mounted quickly and easily, self located in center of the pipe.
- Beveling and grooving with high speed, light weight, good rigidity. Used for the welding preparation.
- Can process facing, flange, convex surface and seal groove.
- Cold cutting process will not influence the quality of the material of the pipe.
- High quality beveling tool, can process different grades of carbon steels, alloy steel, stainless steel and so on.
- Can process the U, V and J shape of pipe beveling according to the requirements.

Specifications

- Electric: Driven by low-energy consumption electric motor 110V or 220V optional, 50-60Hz
- Pneumatic: Drive by pneumatic motor. Air working pressure: 0.6-0.8Mpa, Air Consuming flux:650-960L/min

Beveling Types

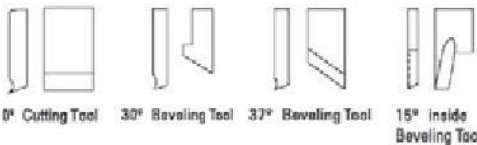

- other bevel angles or alloy steel, cast steel, please declare before order

Technical Parameter

Model No.	Size	Working Range (ID mm)	Wall Thickness (mm)	Rated power (KW)	Rotating Rate (rpm)
Electric:SDC Pneumatic: TCM	80T	28-76	≤ 15	0.9	53
	120T	45-93	≤ 20	1.43	34
	150T	65-159	≤ 20	1.43	34
	350T	150-330	≤ 20	1.43	34

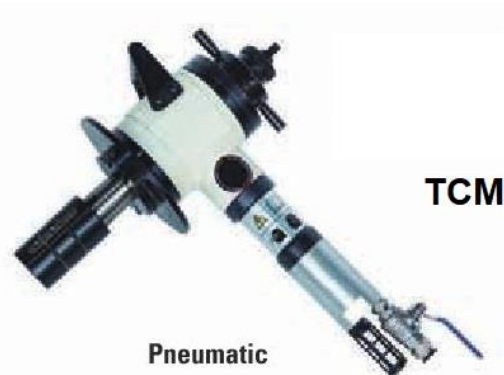

Y-Type Beveling Machine

Product Description

- The Beveling Machine adopts “Y” shape struction design, minimal radial space, light weight, easy to carry, safe use.
- Inner mounted quickly and easily, self located in center of the pipe.
- Beveling and grooving with high speed, light weight, good rigidity. Used for the welding preparation.
- Can process facing, flange, convex surface and seal groove.
- Cold cutting process will not influence the quality of the material of the pipe.
- High quality beveling tool, can process different grades of carbon steels, alloy steel, stainless steel and so on.
- Can process the U, V and J shape of pipe beveling according to the requirements.

Specifications

- Electric: Driven by low-energy consumption electric motor 110V or 220V optional, 50-60Hz
- Pneumatic: Driven by pneumatic motor. Air working pressure: 0.6-0.8Mpa, Air Consuming flux: 650-960L/min

Beveling Types

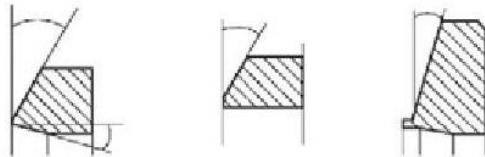

- other bevel angles or alloy steel, cast steel, please declare before order

Technical Parameter

Model No.	Size	Capacity (ID mm)	Wall thickness(mm)	Rated Power (KW)	Rotating Speed(rpm)
Electric: ISY Pneumatic: TCM	150	60-170	≤ 15	1.43	30
	250	80-240	≤ 15	1.43	16
	351	150-330	≤ 15	1.43	10
	630	300-600	≤ 15	1.43	8
	850	600-820	≤ 15	2.0	7

Model No.	Size	Capacity (ID mm)	Wall thickness(mm)	Rated Power (KW)	Rotating Speed(rpm)
Electric: ISY Pneumatic: TCM	250-II	80-240	≤ 75	1.43	16
	351-II	150-330	≤ 75	1.43	10
	630-II	300-600	≤ 75	1.43	8
	850-II	600-820	≤ 75	2.0	7

ISY



ISY-II



Magnetic Drill Series (Multi-functional)

Product Description

- Magnetic drills are a more efficient way to drill a hole through steel. This light weight, portable machine is held in place by a strong magnetic base plate. It's capable of cutting very accurate holes into steel plate and castings. For boring, clean and accurate holes these broachers are ideal for industrial use.
- High power with small size and light weight.
- With constant power soft-starting and electric stepless speed-control.
- With over-loading protection.
- High adhesion



BL-13

BL-16

RI-19

BL-23

BL-28

Magnetic Drill Series (Multi-functional)

Product Description

- Magnetic drills are a more efficient way to drill a hole through steel. This light weight, portable machine is held in place by a strong magnetic base plate. For boring, clean and accurate holes these broachers are ideal for industrial use.
- High power with small size and light weight.
- With constant power soft-starting and mechanical speed control.
- With over-loading protection.
- High adhesion



BL-32

BL-38

BL-49

BL-60

BL-80

Technical Specifications

MODEL	MAX. DRILLING CAPACITY	MAX. ANNULAR CUTTING CAPACITY	MAX. TAPPING CAPACITY	RATED INPUT POWER	MAGNETIC ADHESION	NO-LOAD SPEED	SOFT START	OVERLOAD PROTECTION	STEPLESS SPEED CONTROL	REVERSIBLE
BL-13	13mm	○	○	880 W	8500 N	790 RPM	●	●	○	○
BL-13E	13mm	○	○	880 W	8500 N	0-790 RPM	●	●	●	○
BL-13RE	13mm	○	5mm	880 W	8500 N	0-790 RPM	●	●	●	●
BL-16	16mm	○	○	1100 W	11100 N	680 RPM	●	●	○	○
BL-16E	16mm	○	○	1100 W	11100 N	0-680 RPM	●	●	●	○
BL-16RE	16mm	○	8mm	1100 W	11100 N	0-680 RPM	●	●	●	●
BL-19	19mm	○	○	1150 W	12000 N	350 RPM	●	●	○	○
BL-19E	19mm	50mm	○	1150 W	12000 N	0-350 RPM	●	●	●	○
BL-19RE	19mm	50mm	16mm	1150 W	12000 N	0-350 RPM	●	●	●	●
BL-23	23mm	○	○	1250 W	13000 N	330 RPM	●	●	○	○
BL-23E	23mm	50mm	○	1250 W	13000 N	0-330 RPM	●	●	●	○
BL-23RE	23mm	50mm	16mm	1250 W	13000 N	0-330 RPM	●	●	●	●
BL-28	28mm	○	○	1450 W	13800 N	300 RPM	●	●	○	○
BL-28E	28mm	68mm	○	1450 W	13800 N	0-300 RPM	●	●	●	○
BL-28RE	28mm	68mm	22mm	1450 W	13800 N	0-300 RPM	●	●	●	●

Ordering Information

Catalog No.	Model No.	Description	N.W(kg)
1541010	BL-13	Magnetic Drill, 110V/50-60Hz	11.5
1541110	BL-13E	Magnetic Drill, 110V/50-60Hz	11.5
1541210	BL-13RE	Magnetic Drill, 110V/50-60Hz	11.5
1541310	BL-16	Magnetic Drill, 110V/50-60Hz	11.9
1541410	BL-16E	Magnetic Drill, 110V/50-60Hz	11.9
1541510	BL-16RE	Magnetic Drill, 110V/50-60Hz	11.9
1541610	BL-19	Magnetic Drill, 110V/50-60Hz	22.5
1541710	BL-19E	Magnetic Drill, 110V/50-60Hz	22.5
1541811	BL-19RE	Magnetic Drill, 110V/50-60Hz	22.5
1541910	BL-23	Magnetic Drill, 110V/50-60Hz	22.5
1542010	BL-23E	Magnetic Drill, 110V/50-60Hz	22.5
1542110	BL-23RE	Magnetic Drill, 110V/50-60Hz	22.5
1542210	BL-28	Magnetic Drill, 110V/50-60Hz	23.5
1542310	BL-28E	Magnetic Drill, 110V/50-60Hz	23.5
1542410	BL-28RE	Magnetic Drill, 110V/50-60Hz	23.5

Catalog No.	Model No.	Description	N.W(kg)
1541011	BL-13	Magnetic Drill, 220V/50-60Hz	11.5
1541111	BL-13E	Magnetic Drill, 220V/50-60Hz	11.5
1541211	BL-13RE	Magnetic Drill, 220V/50-60Hz	11.5
1541311	BL-16	Magnetic Drill, 220V/50-60Hz	11.9
1541411	BL-16E	Magnetic Drill, 220V/50-60Hz	11.9
1541511	BL-16RE	Magnetic Drill, 220V/50-60Hz	11.9
1541610	BL-19	Magnetic Drill, 220V/50-60Hz	22.5
1541711	BL-19E	Magnetic Drill, 220V/50-60Hz	22.5
1541810	BL-19RE	Magnetic Drill, 220V/50-60Hz	22.5
1541911	BL-23	Magnetic Drill, 220V/50-60Hz	22.5
1542011	BL-23E	Magnetic Drill, 220V/50-60Hz	22.5
1542111	BL-23RE	Magnetic Drill, 220V/50-60Hz	22.5
1542211	BL-28	Magnetic Drill, 220V/50-60Hz	23.5
1542311	BL-28E	Magnetic Drill, 220V/50-60Hz	23.5
1542411	BL-28RE	Magnetic Drill, 220V/50-60Hz	23.5

CUTTING, DRILLING & BEVELING

Technical Specifications

MODEL	MAX. DRILLING CAPACITY	MAX. ANNULAR CUTTING CAPACITY	MAX. TAPPING CAPACITY	RATED INPUT POWER	MAGNETIC ADHESION	NO-LOAD SPEED	SOFT START	OVERLOAD PROTECTION	MECHANICAL SPEED CONTROL	REVERSIBLE
BL-32	32mm	○	24mm	1700 W	14500 N	280 RPM	●	●	○	●
BL-32RC	32mm	○	24mm	1700 W	14500 N	150/280 RPM	●	●	2 SHAFTS	●
BL-32RCE	32mm	○	24mm	1700 W	14500 N	75/150/280 RPM	●	●	3 SHAFTS	●
BL-38	38mm	○	26mm	1830 W	15500 N	250 RPM	●	●	○	●
BL-38RC	38mm	○	26mm	1830 W	15500 N	135/250 RPM	●	●	2 SHAFTS	●
BL-38RCE	38mm	○	26mm	1830 W	15500 N	70/135/250 RPM	●	●	3 SHAFTS	●
BL-49	49mm	○	30mm	2000 W	16500 N	220 RPM	●	●	○	●
BL-49RC	49mm	○	30mm	2000 W	16500 N	120/220 RPM	●	●	2 SHAFTS	●
BL-49RCE	49mm	○	30mm	2000 W	16500 N	65/120/220 RPM	●	●	3 SHAFTS	●
BL-60	60mm	○	30mm	2750 W	19500 N	205 RPM	●	●	○	●
BL-60RC	60mm	○	30mm	2750 W	19500 N	105/205 RPM	●	●	2 SHAFTS	●
BL-60RCE	60mm	○	30mm	2750 W	19500 N	60/105/205 RPM	●	●	3 SHAFTS	●
BL-80	80mm	○	30mm	2850 W	20000 N	185 RPM	●	●	○	●
BL-80RC	80mm	○	30mm	2850 W	20000 N	95/185 RPM	●	●	2 SHAFTS	●
BL-80RCE	80mm	○	30mm	2850 W	20000 N	50/95/185 RPM	●	●	3 SHAFTS	●

Ordering Information

Catalog No.	Model No.	Description	N.W(kg)
1542510	BL-32	Magnetic Drill, 380V/50-60Hz	53
1542610	BL-32RC	Magnetic Drill, 380V/50-60Hz	53
1542710	BL-32RCE	Magnetic Drill, 380V/50-60Hz	53
1542810	BL-38	Magnetic Drill, 380V/50-60Hz	53
1542910	BL-38RC	Magnetic Drill, 380V/50-60Hz	53
1543010	BL-38RCE	Magnetic Drill, 380V/50-60Hz	53
1543110	BL-49	Magnetic Drill, 380V/50-60Hz	53
1543210	BL-49RC	Magnetic Drill, 380V/50-60Hz	53
1543310	BL-49RCE	Magnetic Drill, 380V/50-60Hz	53
1543410	BL-60	Magnetic Drill, 380V/50-60Hz	60
1543510	BL-60RC	Magnetic Drill, 380V/50-60Hz	60
1543610	BL-60RCE	Magnetic Drill, 380V/50-60Hz	60
1543710	BL-80	Magnetic Drill, 380V/50-60Hz	60
1543810	BL-80RC	Magnetic Drill, 380V/50-60Hz	60
1543910	BL-80RCE	Magnetic Drill, 380V/50-60Hz	60

Magnetic Drill Series (Multi-functional)



BL-2800E

BL-3800E

BL-6800E

BL-7800E

BL-9800E

BL-1280E

Technical Specifications

MODEL	MAX. DRILLING CAPACITY	MAX. ANNULAR CUTTING CAPACITY	MAX. TAPPING CAPACITY	RATED INPUT POWER	MAGNETIC ADHESION	NO-LOAD SPEED	SOFT START	OVERLOAD PROTECTION	STEPLESS SPEED CONTROL	REVERSIBLE	Tool Holder	
BJ-2800E	○	28mm	○	1480 W	13000 N	0-680 RPM	●	●	●	○	Weldon Shank 3/4"	
BJ-3800E	○	38mm	○	1620 W	14500 N	0-650 RPM	●	●	●	○	Weldon Shank 3/4"	
BJ-6800E	○	23mm	68mm	○	1720 W	15800 N	0-580 RPM	●	●	●	○	2 # Morse
BJ-7800E	○	23mm	78mm	○	1880 W	16500 N	0-550 RPM	●	●	●	○	2 # Morse
BJ-9800E	○	28mm	98mm	○	2080 W	16800 N	0-520 RPM	●	●	●	○	3 # Morse
BJ-1280E	○	28mm	128mm	○	2180 W	17000 N	0-500 RPM	●	●	●	○	3 # Morse

Ordering Information

Catalog No.	Model No.	Description	N.W(kg)
1535710	BJ-2800E	Magnetic Drill, 110V/50-60Hz	11.8
1544511	BJ-3800E	Magnetic Drill, 110V/50-60Hz	11.8
1535810	BJ-6800E	Magnetic Drill, 110V/50-60Hz	22
1535910	BJ-7800E	Magnetic Drill, 110V/50-60Hz	22
1536010	BJ-9800E	Magnetic Drill, 110V/50-60Hz	24
1536110	BJ-1280E	Magnetic Drill, 110V/50-60Hz	24

Catalog No.	Model No.	Description	N.W(kg)
1535711	BJ-2800E	Magnetic Drill, 220V/50-60Hz	11.8
1544510	BJ-3800E	Magnetic Drill, 220V/50-60Hz	11.8
1535811	BJ-6800E	Magnetic Drill, 220V/50-60Hz	22
1535911	BJ-7800E	Magnetic Drill, 220V/50-60Hz	22
1536011	BJ-9800E	Magnetic Drill, 220V/50-60Hz	24
1536111	BJ-1280E	Magnetic Drill, 220V/50-60Hz	24